



# OWNER'S MANUAL

**GEN-12™ SBM**

**SEMI-AUTOMATIC**

**12 GAUGE**

## TABLE OF CONTENTS

<u>TOPIC</u>	<u>PAGE</u>
SPECIFICATIONS AND PURCHASE INFORMATION	p. 2
DISASSEMBLY	p. 4
Main Modular Sub-Assemblies	p. 4
Bolt Carrier Group	p. 5
Handguard	p. 7
Barrel Assembly	p. 7
Magazine	p. 8
ASSEMBLY / LUBRICATION	p. 9
Bolt Carrier Group	p. 9
Barrel Assembly	p. 10
Handguard	p. 10
Magazine	p. 10
LOADING AND FIRING	p. 11
AMMUNITION	P. 12
ROUTINE MAINTENANCE	P. 13
PARTS LIST	p. 15
LIMITED WARRANTY INFORMATION	p. 16
GENESIS ARMS CONTACT INFORMATION AND NOTES	P. 17

### FIREARMS SAFETY GUIDELINES

- Firearms are LOADED until you absolutely know otherwise.
- Always keep the muzzle of any firearm pointed in a safe direction.
- Prevent child related accidents by safely storing firearms, unloaded and securely locked out of the reach of children.
- Always wear appropriate eye and ear protection when shooting or near shooting.
- Keep ammunition away from the work area when working on firearms.
- Always wear gloves (nitrile, latex or similar) and appropriate eye protection when using cleaning solvents. Use only cleaning solvents formulated and labeled for firearms use.
- Always have adequate ventilation in any indoor shooting range.
- Local firearms laws may vary greatly. When traveling, always check the laws of any State and/or municipality you may visit. Be safe and legal.

### LEAD WARNING

Exposure to lead is known to cause birth defects, reproductive disorders and serious physical harm. Firing in a poorly ventilated space, firearm cleaning, or handling ammunition may expose you to lead. Always have proper ventilation, wash hands and clean work surfaces after exposure or possible exposure to lead.

## SPECIFICATIONS

### The Gen-12™ Semi-Automatic Shotgun and Firearm Suppressor Breacher Model (SBM)

Caliber	12 Gauge 2¾" or 3" Shotgun Shells
Ammunition Capacity	5 or 10 Round Magazine (10 Round Magazine Not Available in Some States)
Weight	7 lb. 12oz. (3.5 kg.)
Lower Receiver	7075 T6 Billet Aluminum
Upper Receiver	7075 T6 Billet Aluminum
Handguard	6061 Aluminum
Barrel	4140 Chromoly Steel
Action	Non-Gas Operated Short Recoil
Accessory Rail	STANAG 2324 Top Rail, M-LOK at 3, 6, & 9 o'clock
Grip	Pistol Grip
Buttstock	Six Position Collapsible or compact stock (not shown)

## PURCHASE INFORMATION

Serial Number \_\_\_\_\_

Date of Purchase \_\_\_\_\_ / \_\_\_\_\_ / 20\_\_\_\_\_

Internet Purchase

GenesisArms.com

Other online retailer

\_\_\_\_\_ (website)

Retail Store

\_\_\_\_\_ (name)

\_\_\_\_\_ (address)

\_\_\_\_\_ (city) \_\_\_\_\_ (state)

Please complete and mail the Warranty Registration Card

## WARNING

### ALTERATIONS OR MODIFICATIONS

Alteration or modification of the Gen-12™ may cause serious harm to you, damage to the Gen-12™ and will void the warranty. The Gen-12™ shotgun and three main modular sub-assemblies are designed and engineered to function safely and reliably as a unit. Any alteration or modification of a sub-assembly or any component part of a sub-assembly may affect the safety and reliability of your Gen-12™.

Figure 1

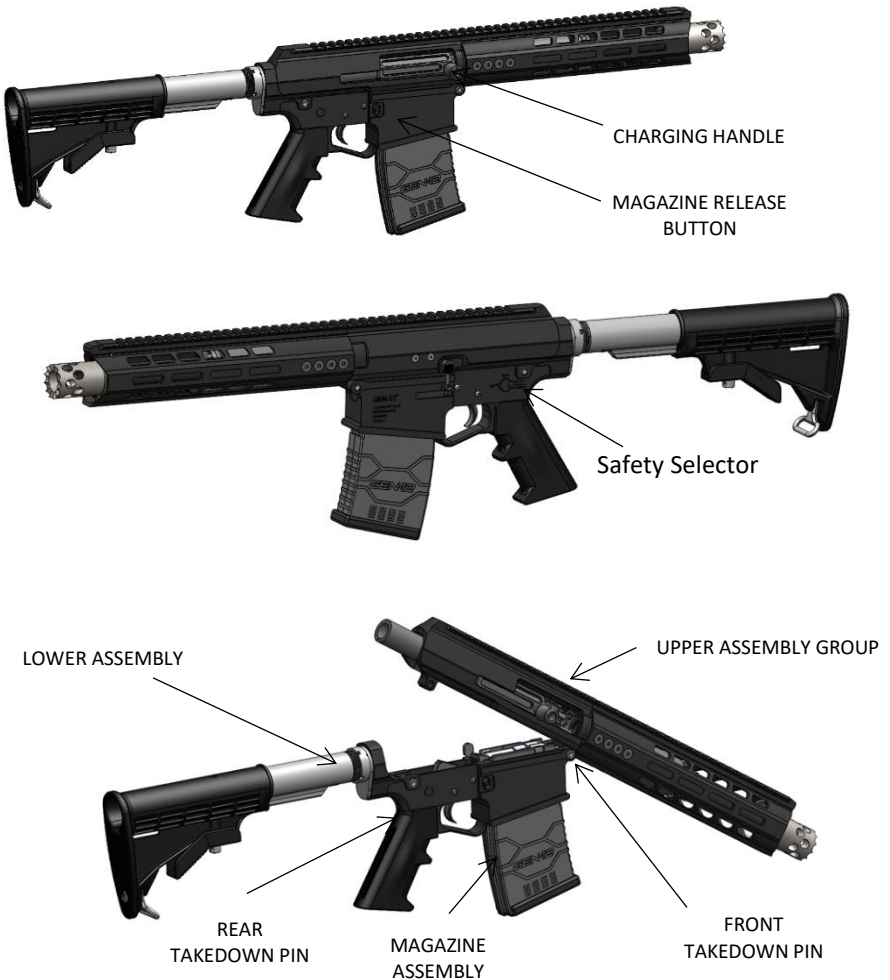

## DISASSEMBLY

### DISASSEMBLY - MAIN MODULAR SUB-ASSEMBLIES

#### RECEIVER ASSEMBLY AND MAGAZINE ASSEMBLY

##### Tools – None

- Have a clean and adequate work area
- Wear appropriate eye protection and gloves
- Point in safe direction
- Set Safety Selector to “Safe” position
- Press Magazine Release Button and remove Magazine
- Pull back Charging Handle to rearmost locked open position
- Verify that Firing Chamber is Empty
- Return Bolt to forward position
- Press Rear Receiver Takedown Pin
- Pivot Upper Receiver Assembly on Front Receiver Pivot Pin
- Press Front Receiver Pivot Pin
- Detach Upper Receiver Assembly from Lower Receiver Assembly

Safety Note – Takedown and Pivot Pin are captive. Do not force or try to remove. Firing Hammer is in the “cocked” position when disassembled. Avoid dry firing the GEN-12™. Dry firing when disassembled will damage the Bolt Catch.

Service Note – Disassembly or repair of Upper Assembly Group or Lower Assembly should be referred to Genesis Arms or certified designee of Genesis Arms, LLC.

Figure 2

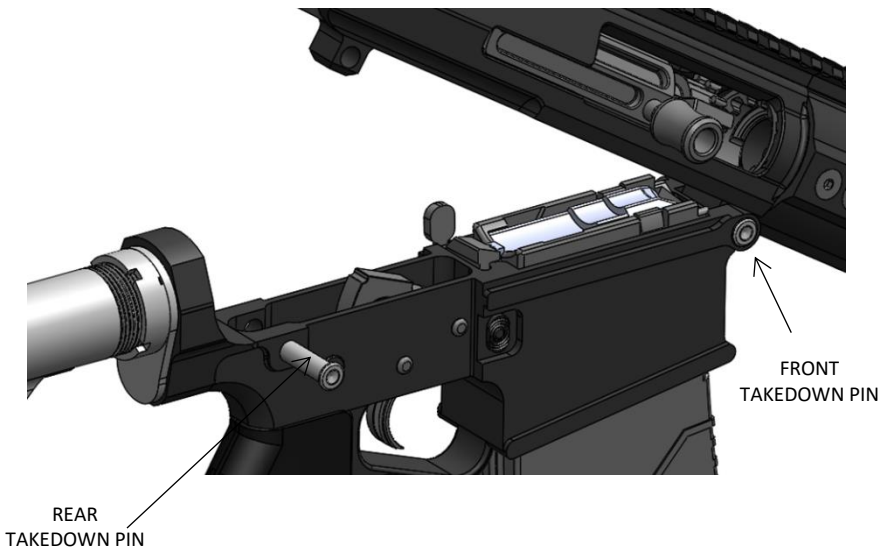

## REMOVAL – BOLT CARRIER GROUP

Figure 3

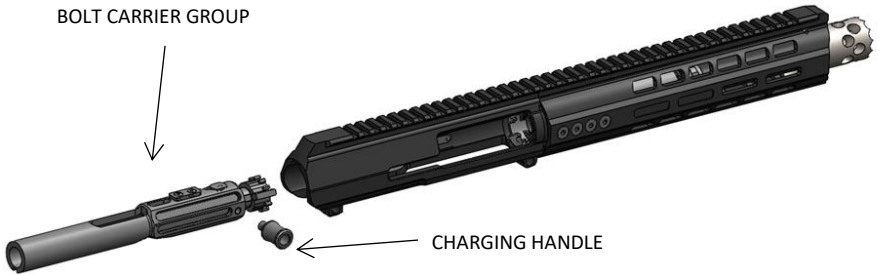

Tools – 1/4" hex (*Allen*) wrench

- Remove Charging Handle using 1/4" hex wrench
- Slide Bolt Carrier Group rearward and remove

## DISASSEMBLY – BOLT CARRIER GROUP

Figure 4

Tools – None

- Remove Firing Pin Cotter Pin
- Remove Firing Pin and Firing Pin Spring
- Remove Cam Pin
- Remove Bolt and Bolt Return Spring
- Remove Extractor Pivot Pins (use Firing Pin or rounded end probe) and Extractors

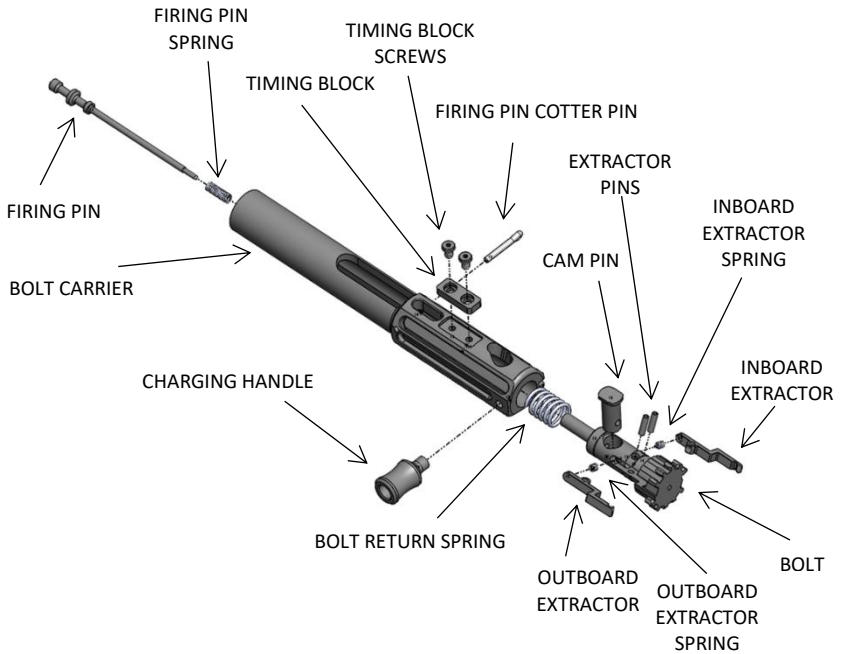

**Safety Note** – Left and Right Extractors and Extractor Springs are not interchangeable (Refer to Figure 4). The Out-Board Extractor has a square nose while the In-Board Extractor has a lead in ramp. The Out-Board Extractor Spring has the stronger spring tension.

Picture 1

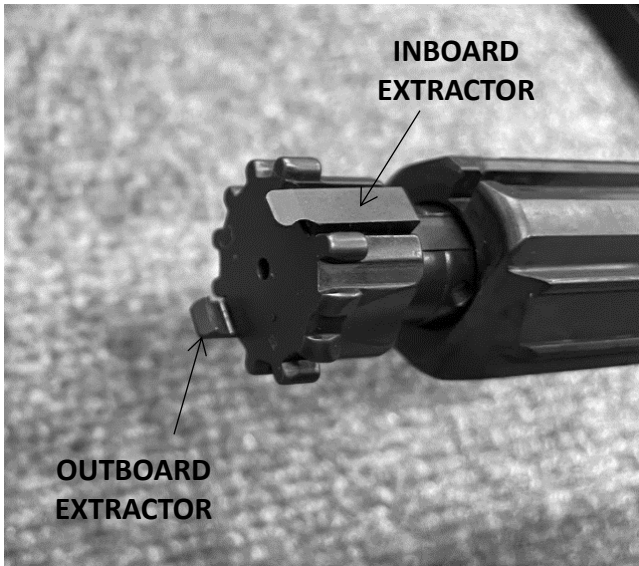

## REMOVAL – HANDGUARD

Figure 5

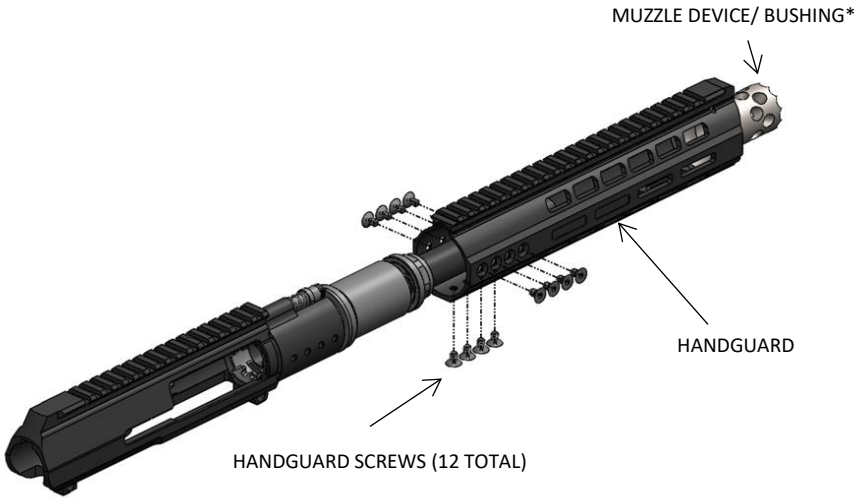

Tools – 1/8" hex (Allen) wrench

- Remove 9 Handguard screws with 1/8" hex wrench
- Remove the Handguard

\*Do not uninstall the bushing. SBM models us a 1.375"-24 muzzle thread and allows for suppressor, standoff device, or blast shields to be interchanged. If you wish to uninstall device, then apply light heat to loosen thread locker.

## REMOVAL – BARREL ASSEMBLY

Figure 6

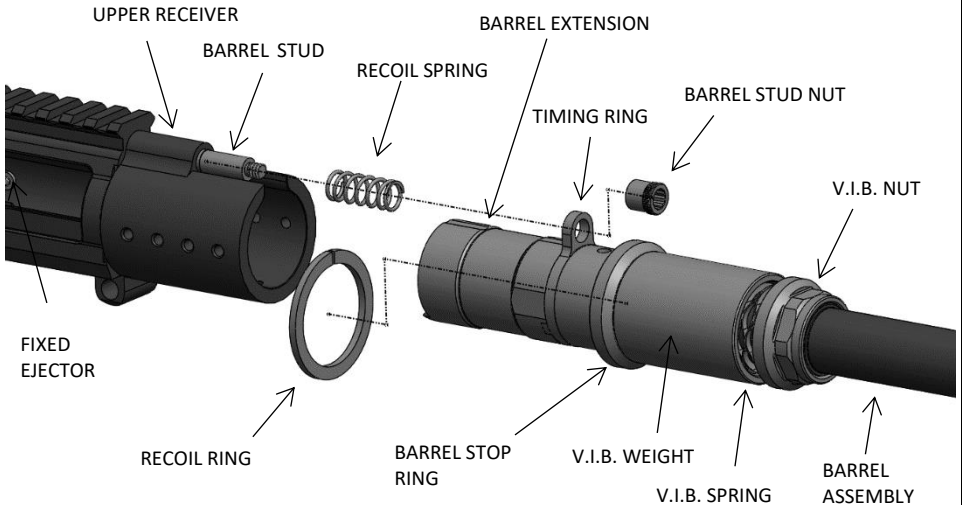



Tools – ¼" hex (Allen) wrench

- Remove Barrel Stud Nut using ¼" hex wrench
- Remove Barrel Assembly and Recoil Spring
- Only remove Recoil Buffer Ring (shown mounted and removed) if replacing

**Safety Note** – Do Not remove Fixed Ejector. If removed, Fixed Ejector must be replaced with a new Fixed Ejector and Ejector Screws (2).

## DISASSEMBLY – MAGAZINE (5 AND 10 ROUND)

Figure 7

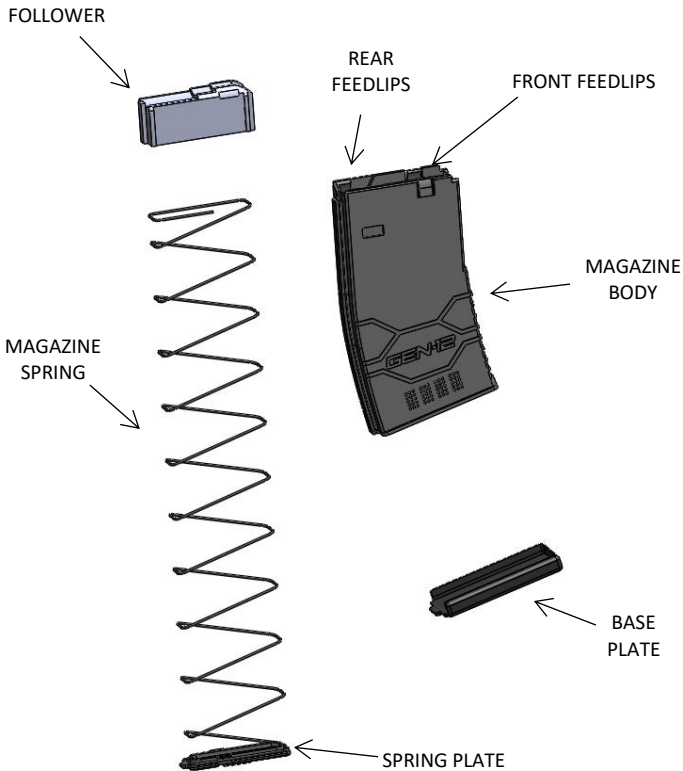

Tools – None

- Remove Base Plate by pressing through the slot in the Spring Plate tab while sliding Base Plate forward
- Remove Spring Plate, Spring and Follower
- Magazine will function longer reliably if stored unloaded

**Safety Note** – Spring Plate is under pressure. Spring Plate and Spring may pop out with force when Base Plate is removed.

## ASSEMBLY / LUBRICATION

Assembly is the reverse of Disassembly with extra steps that should not be ignored.

Lubricate lightly during assembly with any quality gun oil, or motor oil. Please refer to Disassembly Instructions and Figures.

### **ASSEMBLY – BOLT CARRIER GROUP** – Refer to Figures 3 and 4

Tools – 5/32" hex (*Allen*) bit on a *Torque* screwdriver, Gun Oil

- Lubricate Extractors, install with appropriate Springs onto Bolt by compressing each Extractor Spring, align Extractor Pivot Pin Hole, insert each Extractor Pivot Pin
- Extractors should pivot, compress and release with pressure. The outboard extractor should move but should feel heavy resistance, while the inboard extractor should move with minimal resistance.
- Lubricate Bolt, Install Bolt Return Spring onto Bolt
- Insert Bolt into Bolt Carrier \*
- Insert Cam Pin into Bolt, align Cam Pin groove front to back
- Lubricate Firing Pin, install Firing Pin with Firing Pin Spring into Bolt Carrier and secure with Cotter Pin
- Lubricate Bolt Carrier Group groove in Upper Receiver, insert Bolt Carrier Group, attach Charging Knob with 5/32" hex bit on *Torque* screwdriver, torque to 65 in/lbs. (7.3 Nm). It is recommended a small amount of Loctite® Red 272 *Threadlocker* be applied to the threads of the charging knob

*Safety Note* – *DO NOT assemble Bolt Carrier without installing Firing Pin Spring. Without the rearward resistance of Firing Pin Spring, Firing Pin may move forward and strike shell primer while chambering a shell.*

\* If you attempt to assemble with the Bolt upside down in the Bolt Carrier, the Bolt Carrier Group will strike and damage the Fixed Ejector protruding within Upper Receiver (Figure 6).

Picture 2

Correct Orientation of Bolt Assembly Installed in Carrier



**ASSEMBLY – BARREL AND HANDGUARD** - Refer to Figures 5 and 6

Tools – 1/8" and 1/4" hex (*Allen*) bits for a *Torque* screwdriver, Gun Oil

- Loctite® Blue 242 *Threadlocker*

- If removed, install Aluminum Recoil Ring securely
- Insert Recoil Spring onto Barrel Stud
- Lubricate Barrel Extension Inner and Outer
- Ensure the Barrel V.I.B. weight is able to move freely and rebound on spring tension
- Insert Barrel Assembly into Upper Receiver
- Install Barrel Stud Nut with 1/4" hex bit on *Torque* screwdriver, torque to 75-80 in/lbs. (8.7- 9Nm)
- Apply light coat of Vibra-tite® VC-3 on the upper receiver between the handguard screw points. About one to two drops in each space and spread with finger. Do not let VC-3 into the screw threads on the upper receiver.
- Install Handguard
- Lightly coat threads of 12 Handguard screws with Loctite® Red 272 *Threadlocker*
- Install 12 Handguard screws with 1/8" hex bit on *Torque* screwdriver, torque to 45 in/lbs (5.08 Nm)

Loctite® is a registered trademark of the Henkel Corporation

Vibra-Tite is a registered trademark of ND Industries, Inc.

**ASSEMBLY – GEN-12 SINGLE STACK MAGAZINE** – Refer to Figure 7

Tools – None

- Insert Follower
- Insert Magazine Spring with Spring Plate attached
  - Compress Magazine Spring until Spring Plate is beyond the bottom of Magazine Body
- Insert Base Plate and ensure that Spring Plate tab is securely in slot

*Caution* – *The Magazine Spring is compressed during assembly and may release causing injury if not carefully assembled. Refer to Figure 7.*

## LOADING AND FIRING

### START WITH A SAFE LOCATION AND TARGET

- Shooter and those nearby should wear appropriate eye and hearing protection
- Load Magazine with five or ten shells – **Do Not Overload**
- Point down range
- Set Safety Selector to “Safe”
- Insert Magazine into Lower Receiver
- Pull Charging Handle to rearmost position, release and chamber a shell
- Set Safety Selector to “Fire”
- **Aim and fire**
- Charging Handle will lock in rearmost locked position when Magazine is empty
- Set Safety Selector to “Safe”
- Remove Magazine by pressing Magazine Release Button
- To continue shooting, load another Magazine and repeat

### UNLOADING - ALWAYS UNLOAD for Cleaning, Handling, Storage or Inspection

Tools – None

- Point in safe direction
- Set Safety Selector to “Safe” position
- Press Magazine Release Button and remove Magazine
- Pull back Charging Handle to rearmost locked open position
- Verify that Firing Chamber is Empty

### IF UNLOADING WITH A LIVE SHELL IN THE FIRING CHAMBER

- Point in safe direction
- Set Safety Selector to “Safe” position
- Press Magazine Release Button and remove Magazine
- Tilt the GEN-12™ with Firing Chamber opening toward a soft surface
- Pull back Charging Handle to rearmost locked position, eject shell
- Verify that Firing Chamber is Empty

## AMMUNITION

The Non-Gas Operated Short Recoil action of the Gen-12™ uses force generated by firing to eject the spent shell and chamber the next shell. Adequate shell propellant load is essential for proper operation.

### RECOMMENDED AMMUNITION

Use 12 gauge 2¾' or 3" shotgun ammunition (shotshells or slugs) from a name brand manufacturer.

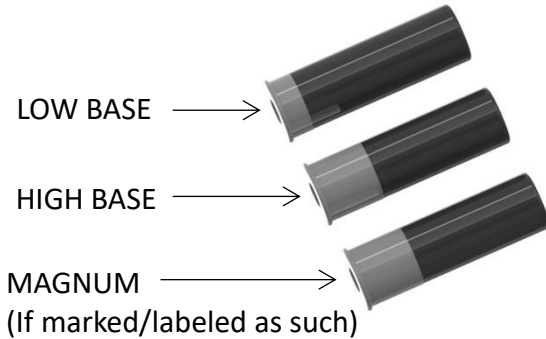

Figure 8

### AMMUNITION LOADS – LOW BASE, HIGH BASE AND MAGNUM

Shotgun ammunition / shells are commonly available in three propellant load levels:

Low Base – usually 2¾ to 3¾ dram equivalent loads;

High Base – usually 3¾ and greater dram equivalent loads; and

Magnum – usually 4 and greater dram equivalent loads.

The GEN-12™ is optimized to cycle High Base non-Magnum load shells with a minimum of 3 dram equivalent load.

The GEN-12™ will cycle Magnum shells. To reduce felt, Genesis recommends using a hydraulic recoil buffer (for example, the Kynshot™ Precision Recoil Damper\*). The addition of a hydraulic recoil buffer may affect the cycling of lower base ammunition. If difficulty is encountered cycling lower base ammunition, reinstall the original non-hydraulic buffer.

***Safety Note*** – Use of reloaded ammunition (“reloads”) is not recommended. Reloads, altered or modified ammunition may cause harm to you, damage your GEN-12™ and will void your warranty.

\* - Kynshot™ is trademark of Kyntec Corporation.

## **ROUTINE MAINTENANCE**

Your GEN-12™ was designed and engineered to provide a lifetime of service. Routine maintenance will preserve your investment. Thorough regular manual or ultrasonic parts cleaning will keep your GEN-12™ in great shape.

These intervals are not absolutes and are meant to be a guide. Depending on the environment, shells discharged, and other variables. It is recommended that inspection, cleaning, and lubrication of the GEN-12 is conducted regularly.

Please refer to Disassembly, Assembly and Lubrication Sections

## **RECOMMENDED MAINTENANCE**

### **FIELD STRIPPING THE GEN-12 (approximately 333 Rounds)**

- Separate upper assembly from the lower assembly
- Clean Barrel Bore with a suitable solvent (optional), bore brush and mop
- Clean Chamber of firing residue
- Clean accessible parts of Lower Receiver of firing residue
- Add light coat of lubrication to bolt carrier group, buffer spring, and upper receiver

### **INTERVAL INSPECTION/ MAINTENANCE (approximately 911 Rounds)**

- Separate the lower assembly from the upper assembly
- Remove the Bolt Carrier Group from the upper (reference page 6).
- Bolt Carrier Group can be broken down into its components but leave the bolt assembly together
- Clean Barrel bore with a suitable solvent, bore brush and mop
- Clean disassembled parts of Carrier and Bolt Assembly of firing residue
- Clean Inner Surfaces of Upper Receiver of firing residue
- Clean accessible parts of Lower Receiver of firing residue
- Lightly Lubricate and assemble component parts disassembled
- Assemble the Gen-12™
- Check trigger pin screws and handguard screws. If they are loose, remove, clean with alcohol or similar, apply Loctite® Blue 243 *Threadlocker* to the screw and install to appropriate torque spec (reference page 10)

### **BEFORE LONG TERM STORAGE**

- Separate the Lower Assembly from the Upper Assembly
- Remove the Bolt Carrier Group from the Upper (reference page 6).
- Bolt Carrier Group can be broken down into its components but leave the Bolt Assembly together
- Clean Barrel bore with a suitable solvent, bore brush and mop
- Swab rubbing alcohol through the chamber and bore to thoroughly remove any solvent
- Clean disassembled parts of Carrier and Bolt Assembly of firing residue

- Clean Inner Surfaces of Upper Receiver of firing residue
- Clean accessible parts of Lower Receiver of firing residue
- Lightly Lubricate and assemble component parts that have been disassembled
- Assemble the Gen-12™
- Store unloaded in a dry non-humid environment

### **MAGAZINE MAINTENANCE**

Clean upper Magazine Body, Follower, Front and Rear Feed-lips of firing residue as needed. The magazine should be clear of debris and the follower should move freely in the body to ensure proper feeding. Magazines are perishable and may need to be replaced after heavy use.

*Safety Note – Only use cleaning products, solvents and lubricants formulated and approved for firearms use. Avoid abrasive cleaners and hard wire brushes. Ultrasonic cleaning rather than abrasives is best for many parts.*

## PARTS LIST

(parts@genesisarms.com for detailed descriptions, diagrams, installation and pricing)

<u>Description</u>	<u>Part Number</u>
Upper Receiver (Empty)	G100-89-P4
Stock	G100-84
Buffer Spring	G100-67
Buffer	G100-68
Grip	G100-71
Bolt	G100-58-P3
Bolt Carrier	G101-50-P3
Charging Knob	G101-78-P4
Bolt Spring	G101-71
Cam Pin	G101-72-P3
Inboard Extractor	G101-67-P3
Inboard Extractor Spring	G101-70
Outboard Extractor	G101-61-P3
Outboard Extractor Spring	G101-64
Extractor Pivot Pins (Set of 2)	G101-66
Firing Pin	G101-74-P2
Firing Pin Retainer Pin	G101-77
Firing Pin Spring	G101-73
Handguard	G101-09-P2
Handguard Screws (Set of 12)	G101-13-P2
Barrel Assembly	G103-10-P2
Barrel Stud Nut	G101-02
Barrel Stud Spring	G101-01
Aluminum Barrel Ring	G101-43-P4
Magazine Complete 5 Round	G100-20
Magazine Box 5 Round	G101-81
Magazine Spring 5 Round	G101-86
Magazine Complete 10 Round **	G100-19
Magazine Box 10 Round **	G101-82
Magazine Spring 10 Round **	G101-87
Magazine Follower ***	G101-85
Magazine Spring Plate ***	G101-88
Magazine Base Plate ***	G101-89
Lower Receiver Parts Kit *	G102-20
Compact Stock (optional)	G100-87

\* Disassembly, repair or replacement of Lower Receiver Assembly Parts should be referred to Genesis Arms or to a Genesis Arms authorized firearms technician.

\*\* 10 Round Magazines and component parts are Not available in all States.

\*\*\* Same parts for 5 or 10 Round Magazines.



## LIMITED WARRANTY

### GENESIS ARMS WARRANTIES ITS PRODUCTS TO BE FREE FROM DEFECTS IN MATERIALS OR WORKMANSHIP

#### Limited Warranty Covers the Original Retail Buyer

For one (1) year plus fourteen (14) days from the date of purchase, Genesis Arms will repair or replace (as determined by Genesis Arms) any Genesis Arms OEM product, bought directly from Genesis Arms or a Genesis Arms authorized dealer, which fails under normal use.

#### Not Covered:

- Products and accessories not purchased from Genesis Arms or Genesis Arms authorized dealer
- Normal wear and tear and cosmetic damage due to use
- Damage or failure due to unauthorized repairs, modifications, alterations, abuse, negligent use or lack of routine maintenance or care
- Damage or failure due to the use of reloaded ("reloads"), altered or defective ammunition

#### ADDITIONAL INFORMATION

The Genesis Arms Limited Warranty is provided in lieu of any and all expressed warranties. All implied warranties, including merchantability, non-infringement and fitness for a particular purpose are limited to the duration, terms and conditions of the Limited Warranty period. No warranties expressed or implied will apply after the duration of the Limited Warranty period. Some states do not allow limitations on the duration of an implied warranty. The preceding limitation of duration may not apply in your home state.

Under the terms of its Limited Warranty, Genesis Arms' responsibility for any malfunction or defects in the product is limited to repair or replacement. The Limited Warranty constitutes Genesis Arms' only obligation to you and your exclusive remedy against Genesis Arms. In no event will Genesis Arms be liable for incidental, special or consequential damages, regardless of whether your claims are based on contract, tort or other theories, including without limitation, any liability for economic loss, bodily injury, property damage or any damage that may result from your use or ownership of a Genesis Arms product, whether foreseeable or not.

Some states do not allow the exclusion or limitation of incidental or consequential damages or certain other exclusions contained in warranties. The preceding limitations and exclusions may not apply in your home state. The declared limitations and exclusions apply to the fullest extent allowed by law.

The Genesis Arms Limited Warranty gives you specific legal rights. You may have other rights which vary from state to state. No person or business is authorized by Genesis Arms to modify any term of the Limited Warranty.

#### For Warranty Work or Questions:

Contact Genesis Arms support@genesisarms.com for Limited Warranty information or to request service. A merchandise return authorization from Genesis Arms is required. Unauthorized returns will not be accepted. When you contact Genesis Arms, please identify the product, serial number, date and place of purchase and a detailed description of the issue. Shipping and insurance charges will be paid by Genesis Arms for products repaired or replaced under its Limited Warranty.

#### Warranty Dispute Resolution:

Any dispute regarding the Limited Warranty will be resolved by Binding Arbitration under the Laws of the State of Idaho to be conducted in Kootenai or Shoshone County, Idaho.





Copyright ©2021 Genesis Arms L.L.C.

All Rights Reserved  
[www.genesisarms.com](http://www.genesisarms.com)