



**OWNER'S MANUAL
GEN-12 SBM
(SUPPRESSOR/BREACHER MODELS)
12 GAUGE**

TABLE OF CONTENTS

<u>Section</u>	<u>Page</u>
1. Specifications	2
2. Advisements	11
3. External Nomenclature	13
4. Handling	14
5. Field Stripping	15
6. Bolt Carrier Group Disassembly	15
7. Upper Receiver Group Disassembly	16
8. Lower Receiver Group Disassembly	17
9. Parts Variants	19
10. Magazine Disassembly	20
11. Cleaning	21
12. Lubrication	21
13. Exploded Diagrams	22
14. Warranty	35

SPECIFICATIONS

MODEL:	GEN-12 SBM 14.5" SBS
<u>DIMENSIONS</u>	
LENGTH	32.5 IN (826mm) COLLAPSED, 35.75IN (908mm)EXTENDED
HEIGHT	7.25 IN (184mm)
WIDTH	2 IN (51mm)
BARREL LENGTH	14.375 IN (365mm)
CHAMBER	2 3/4" & 3" 12 GA
MUZZLE THREAD	1.375" x 24 TPI (HUB compatible)
HANDGUARD LENGTH	14.25 IN (362mm)
WEIGHT (NO MAG)	8 LBS, 6 OZ
MAG WEIGHT (5&10)	5RND- 6.88 OZ, 10RND- 11.84 OZ
<u>FEATURES</u>	
CLASSIFICATION	SHORT BARREL SHOTGUN
OPERATING PRINCIPLE	SHORT RECOIL
LOWER RECEIVER TYPE	GEN1 DPMS .308 PATTERN
LOWER RECEIVER ALLOY	7075 T6 billet aluminum anodized Type III Hardcoat
UPPER RECEIVER TYPE	GENESIS GEN-12 PROPRIETARY
UPPER RECEIVER ALLOY	7075 T6 billet aluminum anodized Type III Hardcoat
HANDGUARD TYPE	FREE FLOAT M-LOK @ 3,6,9 LIGHTWEIGHT
HANDGUARD ALLOY	6061 aluminum anodized Type III Hardcoat
STOCK TYPE	ADAPTIVE TACTICAL EX PERFORMANCE ADJUSTABLE
BUFFER TUBE	MIL SPEC CARBINE 1.150" DIA.
BUFFER SPRING	CARBINE- 11 1/4" 25 COIL ROUND WIRE
BUFFER	.308 SHORT CARBINE 3.8 OZ
BARREL ALLOY	4130 nitride finish
MUZZLE DEVICE	JW MUZZLE DEVICE
TRIGGER TYPE	MIL SPEC
TRIGGER PULL WEIGHT	5.5-8 lbs
SELECTOR TYPE	MIL SPEC
GRIP	HOGUE OVERMOLD
OP HANDLE	RIGHT SIDE

MODEL:	GEN-12 SBM 14.5" FIREARM
<u>DIMENSIONS</u>	
LENGTH	31.25 IN (794mm)
HEIGHT	7.25 IN (184mm)
WIDTH	2 IN (51mm)
BARREL LENGTH	14.375 IN (365mm)
CHAMBER	2 3/4" & 3" 12 GA
MUZZLE THREAD	1.375" x 24 TPI (HUB compatible)
HANDGUARD LENGTH	14.25 IN (362mm)
WEIGHT (NO MAG)	7 LBS, 10 OZ
MAG WEIGHT (5&10)	5RND- 6.88 OZ, 10RND- 11.84 OZ
<u>FEATURES</u>	
CLASSIFICATION	PISTOL GRIP FIREARM
OPERATING PRINCIPLE	SHORT RECOIL
LOWER RECEIVER TYPE	GEN1 DPMS .308 PATTERN
LOWER RECEIVER ALLOY	7075 T6 billet aluminum anodized Type III Hardcoat
UPPER RECEIVER TYPE	GENESIS GEN-12 PROPRIETARY
UPPER RECEIVER ALLOY	7075 T6 billet aluminum anodized Type III Hardcoat
HANDGUARD TYPE	FREE FLOAT M-LOK @ 3,6,9 LIGHTWEIGHT
HANDGUARD ALLOY	6061 aluminum anodized Type III Hardcoat
STOCK TYPE	NONE
BUFFER TUBE	MIL SPEC CARBINE 1.150" DIA.
BUFFER SPRING	CARBINE- 11 1/4" 25 COIL ROUND WIRE
BUFFER	.308 SHORT CARBINE 3.8 OZ
BARREL ALLOY	4130 nitride finish
MUZZLE DEVICE	JW MUZZLE DEVICE
TRIGGER TYPE	MIL SPEC
TRIGGER PULL WEIGHT	5.5-8 lbs
SELECTOR TYPE	MIL SPEC
GRIP	HOGUE OVERMOLD
OP HANDLE	RIGHT SIDE

MODEL:	GEN-12 SBM 10.5" SBS
<u>DIMENSIONS</u>	
LENGTH	28.75 IN (730mm) COLLAPSED, 32 IN (813mm) EXTENDED
HEIGHT	7.25 IN (184mm)
WIDTH	2 IN (51mm)
BARREL LENGTH	10.625 IN (270mm)
CHAMBER	2 3/4" 12 GA LESS LETHAL ONLY
MUZZLE THREAD	1.375" x 24 TPI (HUB compatible)
HANDGUARD LENGTH	10.375 IN (264mm)
WEIGHT (NO MAG)	8 LBS, 6.4 OZ
MAG WEIGHT (5&10)	5RND- 6.88 OZ, 10RND- 11.84 OZ
<u>FEATURES</u>	
CLASSIFICATION	LESS LETHAL (LEO)
OPERATING PRINCIPLE	DELAYED BLOWBACK
LOWER RECEIVER TYPE	GEN1 DPMS .308 PATTERN
LOWER RECEIVER ALLOY	6061 aluminum
UPPER RECEIVER TYPE	GENESIS GEN-12 LL PROPRIETARY
UPPER RECEIVER ALLOY	6061 aluminum
HANDGUARD TYPE	FREE FLOAT M-LOK @ 3,6,9 WITH FULL TOP RAIL
HANDGUARD ALLOY	6061 aluminum
STOCK TYPE	ADAPTIVE TACTICAL EX PERFORMANCE ADJUSTABLE (ORANGE)
BUFFER TUBE	MIL SPEC CARBINE 1.150" DIA.
BUFFER SPRING	CARBINE 10" 24 COIL FLAT WIRE
BUFFER	.308 SHORT CARBINE 3.8 OZ
BARREL ALLOY	4130 nitride finish
MUZZLE DEVICE	LESS LETHAL BLAST CAN
TRIGGER TYPE	MIL SPEC
TRIGGER PULL WEIGHT	5.5-8 lbs
SELECTOR TYPE	MIL SPEC
GRIP	HOGUE OVERMOLD
OP HANDLE	RIGHT SIDE

MODEL:	GEN-12 SBM 10.5" FIREARM
<u>DIMENSIONS</u>	
LENGTH	29 IN (737mm)
HEIGHT	7.25 IN (184mm)
WIDTH	2 IN (51mm)
BARREL LENGTH	10.5 IN (267mm)
CHAMBER	2 3/4" & 3" 12 GA
MUZZLE THREAD	1.375" x 24 TPI (HUB compatible)
HANDGUARD LENGTH	10.375 IN (264mm)
WEIGHT (NO MAG)	7 LBS, 10 OZ
MAG WEIGHT (5&10)	5RND- 6.88 OZ, 10RND- 11.84 OZ
<u>FEATURES</u>	
CLASSIFICATION	PISTOL GRIP FIREARM
OPERATING PRINCIPLE	SHORT RECOIL
LOWER RECEIVER TYPE	GEN1 DPMS .308 PATTERN
LOWER RECEIVER ALLOY	7075 T6 billet aluminum anodized Type III Hardcoat
UPPER RECEIVER TYPE	GENESIS GEN-12 PROPRIETARY
UPPER RECEIVER ALLOY	7075 T6 billet aluminum anodized Type III Hardcoat
HANDGUARD TYPE	FREE FLOAT M-LOK @ 3,6,9 WITH FULL TOP RAIL
HANDGUARD ALLOY	6061 aluminum anodized Type III Hardcoat
STOCK TYPE	NONE
BUFFER TUBE	MIL SPEC CARBINE 1.150" DIA.
BUFFER SPRING	CARBINE- 11 1/4" 25 COIL ROUND WIRE
BUFFER	.308 SHORT CARBINE 3.8 OZ
BARREL ALLOY	4130 nitride finish
MUZZLE DEVICE	STANDARD BLAST CAN WITH CROWN MUZZLE DEVICE
TRIGGER TYPE	MIL SPEC
TRIGGER PULL WEIGHT	5.5-8 lbs
SELECTOR TYPE	MIL SPEC
GRIP	HOGUE OVERMOLD
OP HANDLE	RIGHT SIDE

MODEL:	GEN-12 SBM 7" SBS
<u>DIMENSIONS</u>	
LENGTH	26.875 IN (683mm) COLLAPSED, 30 IN (762mm) EXTENDED
HEIGHT	7.25 IN (184mm)
WIDTH	2 IN (51mm)
BARREL LENGTH	7.25 IN (184mm)
CHAMBER	2 3/4" & 3" 12 GA
MUZZLE THREAD	1.375" x 24 TPI (HUB compatible)
HANDGUARD LENGTH	7 IN (178mm)
WEIGHT (NO MAG)	8 LBS, .48 OZ
MAG WEIGHT (5&10)	5RND- 6.88 OZ, 10RND- 11.84 OZ
<u>FEATURES</u>	
CLASSIFICATION	SHORT BARREL SHOTGUN
OPERATING PRINCIPLE	SHORT RECOIL
LOWER RECEIVER TYPE	GEN1 DPMS .308 PATTERN
LOWER RECEIVER ALLOY	7075 T6 billet aluminum anodized Type III Hardcoat
UPPER RECEIVER TYPE	GENESIS GEN-12 PROPRIETARY
UPPER RECEIVER ALLOY	7075 T6 billet aluminum anodized Type III Hardcoat
HANDGUARD TYPE	FREE FLOAT M-LOK @ 3,6,9 WITH FULL TOP RAIL
HANDGUARD ALLOY	6061 aluminum anodized Type III Hardcoat
STOCK TYPE	ADAPTIVE TACTICAL EX PERFORMANCE ADJUSTABLE
BUFFER TUBE	MIL SPEC CARBINE 1.150" DIA.
BUFFER SPRING	CARBINE- 11 1/4" 25 COIL ROUND WIRE
BUFFER	.308 SHORT CARBINE 3.8 OZ
BARREL ALLOY	4130 nitride finish
MUZZLE DEVICE	STANDARD BLAST CAN WITH CROWN MUZZLE DEVICE
TRIGGER TYPE	MIL SPEC
TRIGGER PULL WEIGHT	5.5-8 lbs
SELECTOR TYPE	MIL SPEC
GRIP	HOGUE OVERMOLD
OP HANDLE	RIGHT SIDE

MODEL:	GEN-12 PDW 7" SBS
DIMENSIONS	
LENGTH	22 IN (559mm) COLLAPSED, 27 IN (686mm)EXTENDED
HEIGHT	7.25 IN (184mm)
WIDTH	2 IN (51mm)
BARREL LENGTH	7.25 IN (184mm)
CHAMBER	2 3/4" & 3" 12 GA
MUZZLE THREAD	1.375" x 24 TPI (HUB compatible)
HANDGUARD LENGTH	7 IN (178mm)
WEIGHT (NO MAG)	7 LBS, 11 OZ
MAG WEIGHT (5&10)	5RND- 6.88 OZ, 10RND- 11.84 OZ
FEATURES	
CLASSIFICATION	SHORT BARREL SHOTGUN
OPERATING PRINCIPLE	SHORT RECOIL
LOWER RECEIVER TYPE	GEN1 DPMS .308 PATTERN
LOWER RECEIVER ALLOY	7075 T6 billet aluminum anodized Type III Hardcoat
UPPER RECEIVER TYPE	GENESIS GEN-12 PROPRIETARY
UPPER RECEIVER ALLOY	7075 T6 billet aluminum anodized Type III Hardcoat
HANDGUARD TYPE	FREE FLOAT M-LOK @3,6,9,12
HANDGUARD ALLOY	6061 aluminum anodized Type III Hardcoat
STOCK TYPE	PDW- PROPRIETARY COMPACT 2 POSITION
BUFFER TUBE	4.3 IN PROPRIETARY
BUFFER SPRING	CARBINE- 10.5" 25 COIL FLAT WIRE
BUFFER	PROPRIETARY 4.4 OZ
BARREL ALLOY	4130 nitride finish
MUZZLE DEVICE	STANDARD BLAST CAN WITH CROWN MUZZLE DEVICE
TRIGGER TYPE	MIL SPEC
TRIGGER PULL WEIGHT	5.5-8 lbs
SELECTOR TYPE	MIL SPEC
GRIP	HOGUE OVERMOLD
OP HANDLE	RIGHT SIDE

MODEL:	GEN-12 MBS 7" AOW
<u>DIMENSIONS</u>	
LENGTH	21.75 IN (552mm)
HEIGHT	7.25 IN (184mm)
WIDTH	2 IN (51mm)
BARREL LENGTH	7.25 IN (184mm)
CHAMBER	2 3/4" & 3" 12 GA
MUZZLE THREAD	1.375" x 24 TPI (HUB compatible)
HANDGUARD LENGTH	7 IN (178mm)
WEIGHT (NO MAG)	6 LBS, 15.44 OZ
MAG WEIGHT (5&10)	5RND- 6.88 OZ, 10RND- 11.84 OZ
<u>FEATURES</u>	
CLASSIFICATION	ANY OTHER WEAPON
OPERATING PRINCIPLE	SHORT RECOIL
LOWER RECEIVER TYPE	GEN1 DPMS .308 PATTERN
LOWER RECEIVER ALLOY	7075 T6 billet aluminum anodized Type III Hardcoat
UPPER RECEIVER TYPE	GENESIS GEN-12 PROPRIETARY
UPPER RECEIVER ALLOY	7075 T6 billet aluminum anodized Type III Hardcoat
HANDGUARD TYPE	FREE FLOAT M-LOK @3,6,9,12
HANDGUARD ALLOY	6061 aluminum anodized Type III Hardcoat
STOCK TYPE	N/A
BUFFER TUBE	STOCKLESS COMPACT BUFFER SYSTEM PROPRIETARY
BUFFER SPRING	CARBINE- 10.5" 25 COIL FLAT WIRE
BUFFER	PROPRIETARY 4.4 OZ
BARREL ALLOY	4130 nitride finish
MUZZLE DEVICE	MICRO BLAST CAN
TRIGGER TYPE	MIL SPEC
TRIGGER PULL WEIGHT	5.5-8 lbs
SELECTOR TYPE	MIL SPEC
GRIP	HOGUE OVERMOLD
OP HANDLE	RIGHT SIDE

MODEL:	GEN-12 SBM 5" SBS
DIMENSIONS	
LENGTH	24 IN (610mm) COLLAPSED, 27 IN (686mm)EXTENDED
HEIGHT	7.25 IN (184mm)
WIDTH	2.065 IN (52mm)
BARREL LENGTH	5.75 IN (146mm)
CHAMBER	2 3/4" 12 GA
MUZZLE THREAD	1.375" x 24 TPI (HUB compatible)
HANDGUARD LENGTH	5.5 IN (140mm)
WEIGHT (NO MAG)	7 LBS, 4.08 OZ
MAG WEIGHT (5&10)	5RND- 6.88 OZ, 10RND- 11.84 OZ
FEATURES	
CLASSIFICATION	SHORT BARREL SHOTGUN
OPERATING PRINCIPLE	SHORT RECOIL
LOWER RECEIVER TYPE	GEN1 DPMS .308 PATTERN
LOWER RECEIVER ALLOY	7075 T6 billet aluminum anodized Type III Hardcoat
UPPER RECEIVER TYPE	GENESIS GEN-12 PROPRIETARY
UPPER RECEIVER ALLOY	7075 T6 billet aluminum anodized Type III Hardcoat
HANDGUARD TYPE	FREE FLOAT M-LOK @ 3,6,9 WITH FULL TOP RAIL
HANDGUARD ALLOY	6061 aluminum anodized Type III Hardcoat
STOCK TYPE	ADAPTIVE TACTICAL EX PERFORMANCE ADJUSTABLE
BUFFER TUBE	MIL SPEC CARBINE 1.150" DIA.
BUFFER SPRING	CARBINE 10" 24 COIL FLAT WIRE
BUFFER	.308 SHORT CARBINE 3.8 OZ
BARREL ALLOY	4130 nitride finish
MUZZLE DEVICE	STANDARD BLAST CAN WITH CROWN MUZZLE DEVICE/SUPPRESSOR
TRIGGER TYPE	MIL SPEC
TRIGGER PULL WEIGHT	5.5-8 lbs
SELECTOR TYPE	MIL SPEC
GRIP	HOGUE OVERMOLD
OP HANDLE	RIGHT SIDE

MODEL:	GEN-12 PDW 5" SBS
<u>DIMENSIONS</u>	
LENGTH	21.125 IN (537mm) COLLAPSED, 26 IN (660mm)EXTENDED
HEIGHT	7.25 IN (184mm)
WIDTH	2.065 IN (52mm)
BARREL LENGTH	5.75 IN (146mm)
CHAMBER	2 3/4" 12 GA
MUZZLE THREAD	1.375" x 24 TPI (HUB compatible)
HANDGUARD LENGTH	5.5 IN (140mm)
WEIGHT (NO MAG)	7 LBS, 4.32 OZ
MAG WEIGHT (5&10)	5RND- 6.88 OZ, 10RND- 11.84 OZ
<u>FEATURES</u>	
CLASSIFICATION	SHORT BARREL SHOTGUN
OPERATING PRINCIPLE	SHORT RECOIL
LOWER RECEIVER TYPE	GEN1 DPMS .308 PATTERN
LOWER RECEIVER ALLOY	7075 T6 billet aluminum anodized Type III Hardcoat
UPPER RECEIVER TYPE	GENESIS GEN-12 PROPRIETARY
UPPER RECEIVER ALLOY	7075 T6 billet aluminum anodized Type III Hardcoat
HANDGUARD TYPE	FREE FLOAT M-LOK @ 3,6,9 WITH FULL TOP RAIL
HANDGUARD ALLOY	6061 aluminum anodized Type III Hardcoat
STOCK TYPE	PDW- PROPRIETARY COMPACT 2 POSITION
BUFFER TUBE	4.3 IN PROPRIETARY
BUFFER SPRING	10.5" 25 COIL FLAT WIRE
BUFFER	PROPRIETARY 4.4 OZ
BARREL ALLOY	4130 nitride finish
MUZZLE DEVICE	STANDARD BLAST CAN WITH CROWN MUZZLE DEVICE/SUPPRESSOR
TRIGGER TYPE	MIL SPEC
TRIGGER PULL WEIGHT	5.5-8 lbs
SELECTOR TYPE	MIL SPEC
GRIP	HOGUE OVERMOLD
OP HANDLE	RIGHT SIDE

ADVISEMENTS

Firearms Safety

Firearms safety is the responsibility of the user. Never assume the condition of a firearm or rely upon others to confirm that a firearm is in a safe condition. It is important to follow the rules of safe firearms handling at all times.

- 1. Always keep the firearm pointed in a safe direction.** A safe direction is defined as any direction that would not endanger people or property.
- 2. Keep your finger off of the trigger until ready to shoot.**
- 3. Keep the firearm unloaded until ready to use.**
- 4. Know your target and what is beyond it.**

Receiver Compatibility

Genesis Arms Gen-12 upper receivers are designed to fit and function properly when paired with a DPMS Gen 1 .308 pattern lower receiver. There are many manufacturers producing this type of lower receiver, however with slight dimensional differences. It is with this fact in mind that **Genesis Arms can only guarantee proper fitment and function of the Gen-12 upper receivers and magazines when paired with Genesis Arms Gen-12 lower receivers.** While Genesis Gen-12 upper receivers will mount to other DPMS Gen 1 .308 pattern lower receivers, magazine fitment and function cannot be guaranteed.

Modifications

Modifications or alterations to any of the Gen-12 parts or assemblies are strongly discouraged and will void any manufacturer warranty. There are parts unique to the Gen-12 short recoil operating system that require precise adjustment to ensure proper and safe operation. **Genesis Arms shall not be responsible for injury, death, or property damage resulting from faulty installation, misuse, modification or alteration of any Genesis product.**

Ammunition

The short recoil operating system of the Gen-12 uses force generated by firing to eject the spent shell and chamber the next shell. Adequate shell propellant load is essential for proper operation. It is therefore recommended that only 12 gauge 2¾” or 3” shotgun ammunition (shotshells or slugs) from a name brand manufacturer are used in the Gen-12.

Shotgun ammunition/ shells are commonly available in three propellant load levels:

Low Base – usually 2¾ to 3¼ dram equivalent loads

High Base – usually 3¼ and greater dram equivalent loads

Magnum - usually 4 and greater dram equivalent loads

The Gen-12 is optimized to cycle High Base non-Magnum load shells with a minimum of 3 dram equivalent load. The Gen-12 will cycle Magnum shells. When shooting Magnum shotshells, Genesis Arms recommends using an appropriate hydraulic recoil buffer in place of the factory

buffer to reduce felt recoil. The addition of a hydraulic recoil buffer may affect the cycling of lower base ammunition. If difficulty is encountered cycling lower base ammunition, reinstall the original nonhydraulic buffer.

Due to varying dimensions of the length and crimp of 3" shotshell hulls, it is recommended to check the fit of 3" shotshells in the Gen-12 magazine to ensure smooth and proper feeding.

Use of reloaded ammunition ("reloads") is not recommended. Remanufactured, nonstandard, reloaded, altered or modified ammunition or ammunition not manufactured to NATO, CIP or SAAMI specifications may cause harm to you, damage your GEN-12 and will void your warranty.

Adhesives and Threadlockers

Due to the recoil generated by 12 gauge shotshells, threadlockers and adhesives are used in the assembly of the Gen-12. Attempting to remove parts from the Gen-12 without addressing this may result in damaged or broken parts and tools. All parts utilizing threadlockers or adhesives will be specifically referenced in this manual and should be removed and reapplied only in the prescribed manner. Follow the manufacturer's instructions for the use of each individual adhesive product.

Lead Warning

Exposure to lead is known to cause birth defects, reproductive disorders and serious physical harm. Firing in a poorly ventilated space, firearm cleaning, or handling ammunition may expose you to lead. Always have proper ventilation, wash hands and clean work surfaces after exposure or possible exposure to lead.

M-LOK Attachments

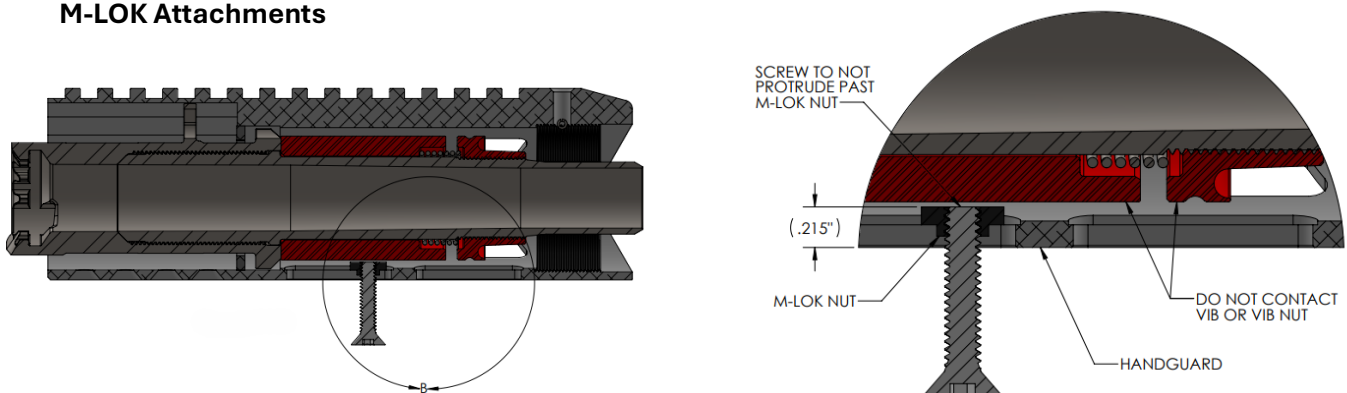

The compact design of the Genesis Arms 5" and 7" barreled models require specific attention when attaching M-LOK accessories to the handguard. The operating system in these models places reciprocating parts (shown in red) in close proximity to the inside of the handguard near the M-LOK attachment slots. **It is important to ensure that the attachment screws do not protrude beyond the inner edge of the M-LOK nut when secured to the handguard (see illustration).** Failure to prevent contact will result in cycling issues and cause damage to your Gen-12.

EXTERNAL NOMENCLATURE

RIGHT SIDE

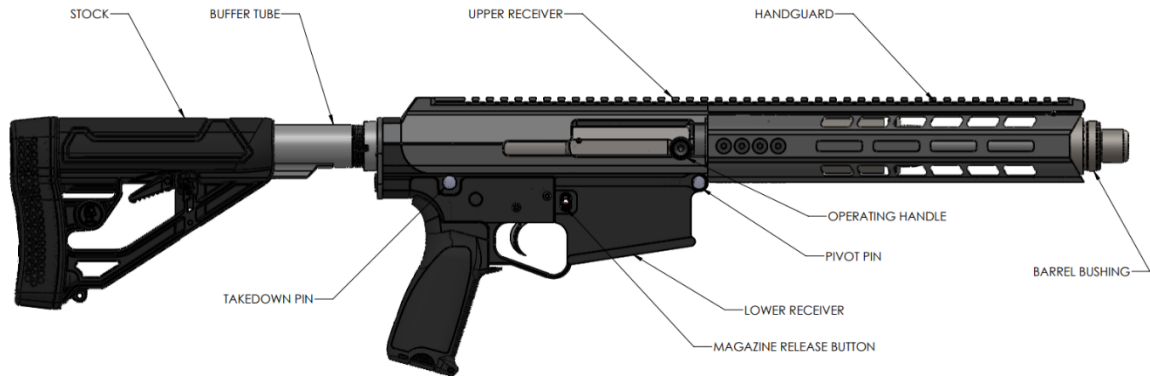

LEFT SIDE

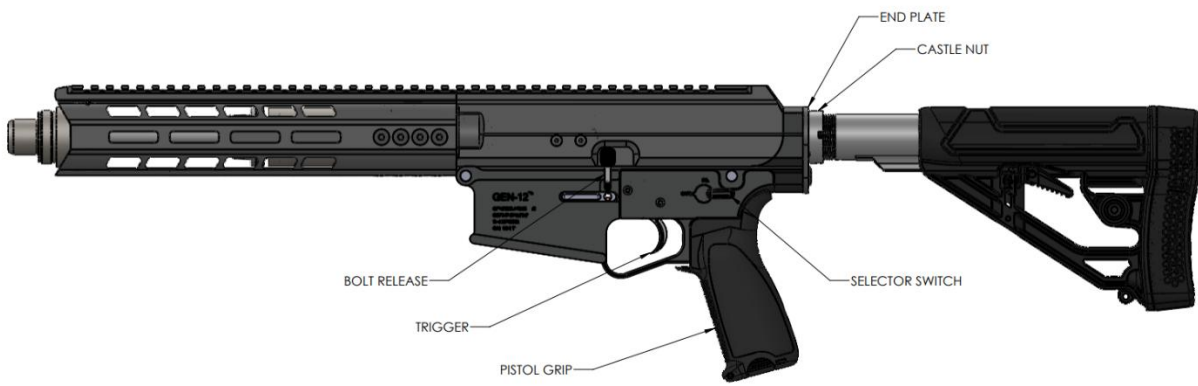

HANDLING

Before handling the condition of the gun must be determined. **A safety check is the only way to definitively know and ensure that the shotgun is unloaded and safe to handle.** This step is critical to the safety of the operator and those in the vicinity. **This process should be performed every time the shotgun is picked up and before the operator does anything to the gun that could result in the trigger being pulled.** Each and every operator/ handler is responsible for performing this task individually... no assumption should be made that a firearm is “clear” of ammunition in any instance, even if told so by another operator/ handler.

Safety Check Procedure

- 1. Keep the shotgun pointed in a safe direction.** A safe direction is defined as any direction in which an accidental discharge would not result in injury to any person or damage of property in the vicinity. Consideration should be given to who or what may be behind a wall, overhead or under a floor.
- 2. Ensure that the selector switch is in the SAFE position.** The Gen-12 utilizes a selector switch located on the left side of the lower receiver (some models use an ambidextrous selector switch) that is clearly marked SAFE and FIRE in the respective locations.
- 3. Remove the magazine.** The magazine release button is located on the right side of the lower receiver forward of the trigger. Depress the button and remove the magazine from the shotgun.
- 4. Open the bolt and lock it fully to the rear.** The operating handle is located on the bolt carrier. Pull the operating handle to the rear of the firearm until it stops, then engage the bolt stop located on the left side of the lower receiver. This will retain the bolt carrier group behind the magazine well in the open position.
- 5. Visually and physically inspect the chamber.** Look into the open ejection port and verify that there is no ammunition present in the shotgun. A finger sweep can be performed to further verify that the shotgun is unloaded in low light situations.

Loading Procedure

- 1. Point shotgun in a safe direction and keep fingers off of the trigger.**
- 2. Ensure the selector is in the SAFE position.**
- 3. Insert a loaded magazine into the lower receiver.**
- 4. Pull operating handle to the rearmost position and release it to load a shell.** If the bolt is locked in the open position prior to inserting the magazine, simply release the bolt from the bolt stop utilizing the control on the left side of the lower receiver.

Unloading Procedure

- 1. Point shotgun in a safe direction and keep fingers off of the trigger.**
- 2. Ensure the selector is in the SAFE position.**
- 3. Press the magazine release button and remove the magazine.**
- 4. Pull operating handle to the rearmost position and engage the bolt stop.**
- 5. Visually and physically inspect the chamber for ammunition.**

FIELD STRIP PROCEDURE

Basic disassembly or “field stripping” a firearm is the process of breaking down a complete firearm into its constituent groups for the purpose of inspection, cleaning or clearing obstructions. When field stripped the Gen-12 is disassembled into three groups: the lower receiver group, upper receiver group and bolt carrier group.

Before attempting to field strip the shotgun perform a safety check.

1. Starting with the bolt closed and magazine removed, push the takedown pin and the pivot pin from left to right until the lower receiver is separated from the upper receiver. The pivot and takedown pins are retained in the lower receiver after disassembly and are not removed from the lower assembly in this procedure.
2. Remove the operating handle(s) from the bolt carrier in the upper assembly. There are two methods available for removing the operating handle, either with a 5/32” hex wrench inserted into the center of the handle, or a punch, screwdriver etc. placed through the sides of the handle. Turn the handle counterclockwise to remove. The operating handle is retained securely in the bolt carrier and may require some effort to break it loose.
3. Remove the bolt carrier group from the rear of the upper receiver.
4. Depress the buffer retainer and remove the buffer and buffer spring in a controlled manner.

BOLT CARRIER GROUP DISASSEMBLY

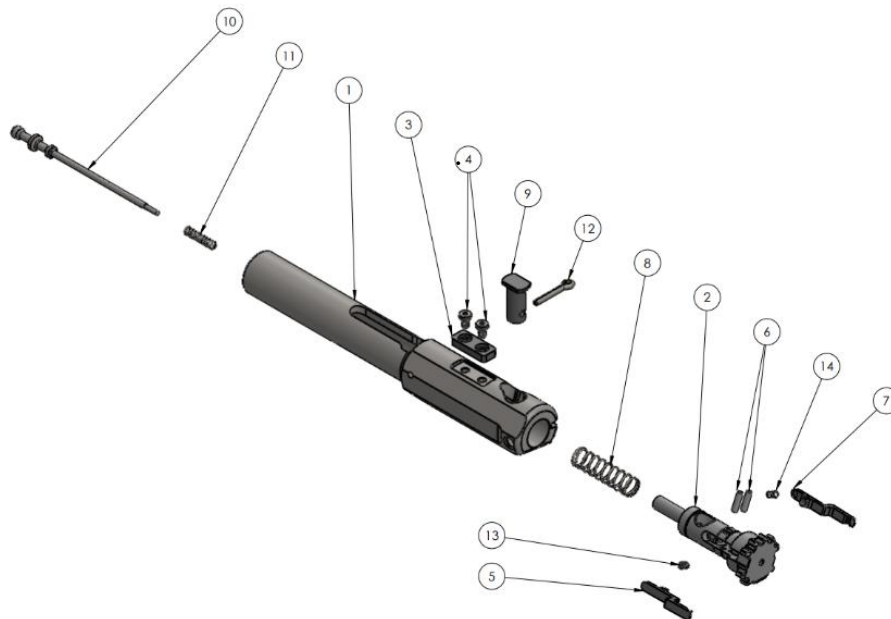

1. Remove the firing pin retainer (#12).
2. Remove the firing pin (#10) and firing pin spring (#11).
3. Remove the cam pin (#9).
4. Remove the bolt (#2) and bolt return spring (#8) from the bolt carrier (#1).
5. Remove the extractors (#5 & #7) by pushing out the extractor pins (#6) from the bolt (#2)*.

NOTES:

***The extractors of the Gen-12 bolt are not interchangeable.** The outboard extractor (#5) has a square nose while the inboard extractor (#7) has a lead-in ramp. The outboard extractor uses a heavier spring (#13) than that of the inboard extractor (#14) and should never be interchanged. The extractors should only be removed if necessary for inspection, deep cleaning or replacement.

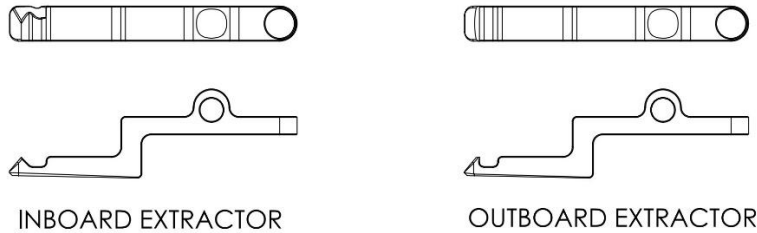

***Do not remove the timing block (#3) from the top of the bolt carrier as it is secured with Loctite 272 and considered a permanent installation.**

UPPER RECEIVER GROUP DISASSEMBLY

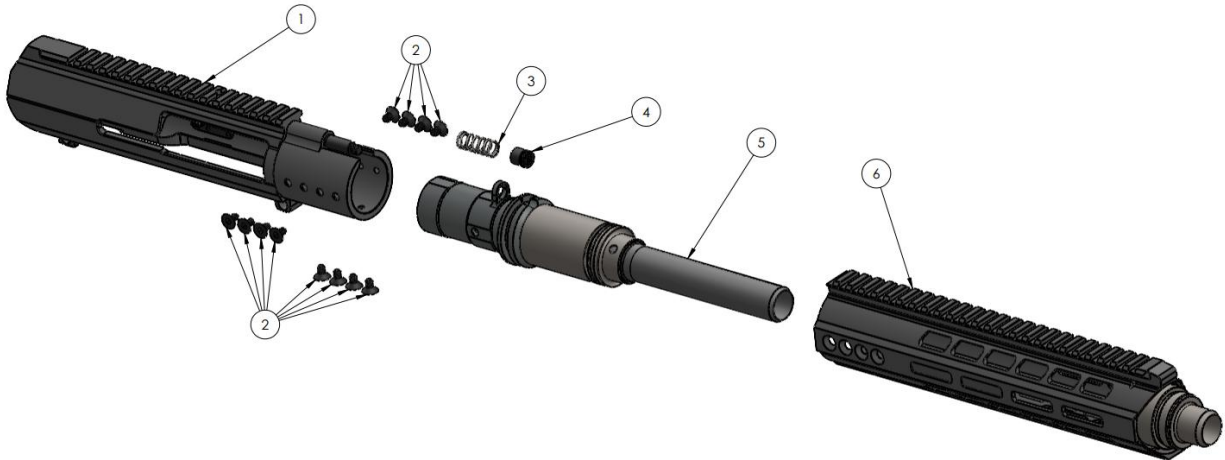

1. Remove the 12 handguard screws (#2) with a 1/8" hex wrench. The handguard screws are secured with Loctite 272 and may require light heat be applied to loosen without damaging the screw heads.
2. Remove the handguard (#6) by sliding the assembly forward. The handguard is installed utilizing Vibra-tite VC-3 between the handguard and upper receiver and may require light heat to aid in removal.
3. Remove the barrel stud nut (#4) using a 1/4" hex wrench.
4. Remove the barrel by sliding the assembly (#5) forward and out of the upper receiver. The recoil spring (#3) can be removed from the barrel stud at this point.

NOTES:

***Removal of the barrel bushing/ barrel true from the handguard is not advised.** These parts are installed with Loctite 272 to a specific location and then drilled and pinned. Attempted removal can result in damage to the associated threads and require Factory Service.

***Do not remove the recoil ring from the barrel extension unless there is a need to replace it.**

NOTES cont.:

***The barrel extension and VIB nut should not be removed from the barrel as these parts are considered a permanent installation** as they are secured with Loctite 272 and staked to their respective threads. Any attempt to remove these parts will permanently damage the barrel assembly.

***The barrel stud, wear insert and fixed ejector should not be removed from the upper receiver as they are installed with Loctite 272 and torqued to prevent loosening.**

LOWER RECEIVER GROUP DISASSEMBLY

Do not dry fire the hammer or allow the hammer to drop in an uncontrolled manner when the lower receiver is separated from the upper receiver. Doing so can result in damage to the bolt catch due to the impact from the hammer.

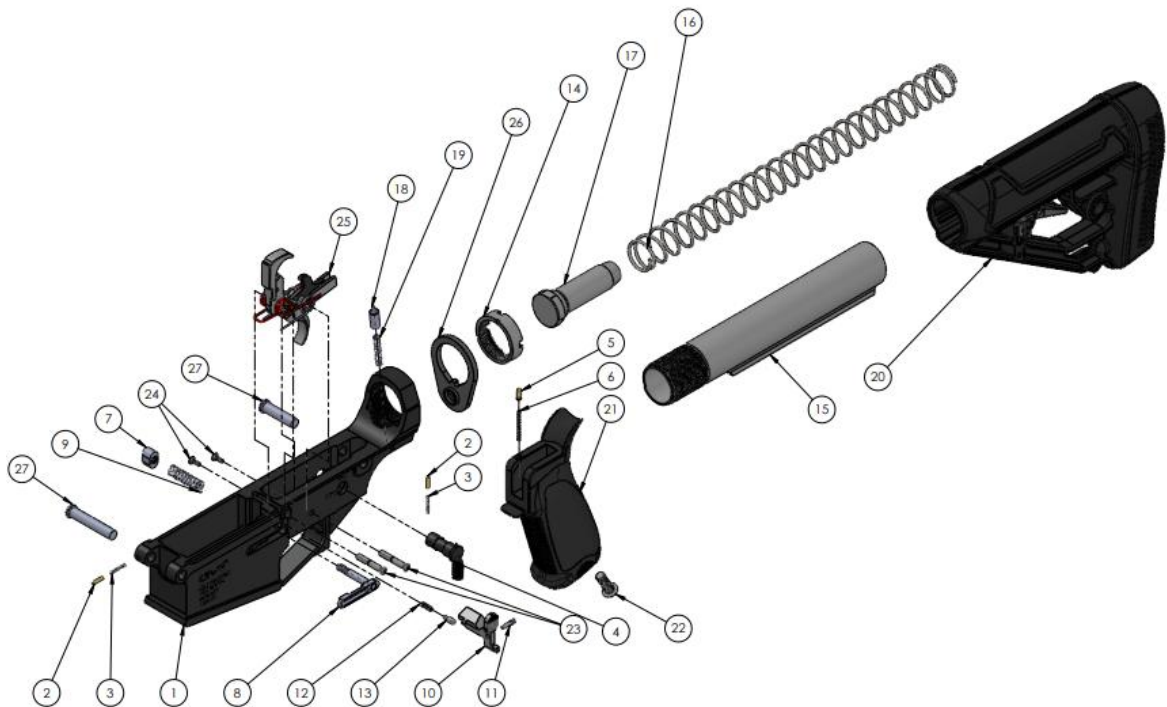

1. Remove the grip (#21) from the lower receiver (#1) using a 5/32" hex wrench inserted through the bottom of the grip. Watch for the selector spring (#6) and takedown detent spring (#3) retained by the grip on the right side of the lower receiver. As the grip is loosened the springs will become visible. Caution should be exercised to prevent loss or damage to these springs. Remove the springs and respective detents (#5 & #2)- a light tap on the palm of your hand may aid in removal of the detents.
2. Remove the takedown pin (#27) from the right side of the receiver.
3. Remove the selector switch (#4) from the left side of the receiver. It may be necessary to ensure that the hammer is in the cocked position to allow the selector to be removed. For ambidextrous selectors, remove the right side control using a 5/64" hex wrench prior to disassembly.
4. Remove the hammer pin retaining screw (#24) from one side of the receiver. The screw is secured using Loctite 242 and may require some effort to break loose. Using a pair of T10 Torx wrenches on opposite sides of the pin, turn one wrench counterclockwise while

holding the other stationary. Once the screw breaks loose, remove the screw leaving the pin in place.

5. Lower the hammer to the fired position in a controlled manner. Hold the hammer securely as it is under spring pressure. Push the hammer pivot pin (#23) out of the receiver from the side the retaining screw was removed using a punch and carefully remove the hammer assembly from the lower receiver.
6. Remove the trigger pin retaining screw (#24) from one side of the receiver using the same procedure as the hammer pin.
7. Push the trigger pivot pin out of the receiver from the side the retaining screw was removed. Use caution as the trigger and disconnecter are under spring pressure. Capture the disconnecter and trigger assembly and remove from the lower receiver.
8. Remove the bolt catch screw (#11) using a 1/16" hex wrench. The bolt catch screw is installed using Loctite 242 and is lightly staked to prevent the screw from backing out. This step should only be performed if the removal of the bolt catch is necessary.
9. Remove the bolt catch (#10), bolt catch spring (#12) and follower (#13) from the lower receiver.
10. Using a non-marring punch, depress the magazine catch button (#7) fully and unscrew the magazine catch from the button by rotating the catch counterclockwise on the left side of the lower receiver. Once unthreaded, the magazine catch button becomes loose and is under spring pressure so be sure to anticipate this and retain the button and spring (#9).
11. Buffer tube removal: This step is only necessary if the buffer tube has become damaged or otherwise needs to be replaced. The buffer tube and castle nut are secured to the lower receiver with Loctite 242 and may require some effort to break loose. With this in mind the buffer tube can be removed with the following procedure:
 - Using a buffer tube castle nut tool or combination tool, thread the castle nut (#14) counterclockwise away from the lower receiver. If the castle nut is too tight to remove in a controlled manner, the application of light heat to the nut will help loosen the Loctite.
 - Once the castle nut is backed away from the lower receiver far enough to free up the end plate (#26), slide the end plate away from the lower receiver behind the castle nut.
 - CAUTION: The buffer retainer (#18) is under spring tension and will jump out of the lower receiver when the buffer tube is unthreaded approximately ¼ turn. Control the buffer retainer by placing your thumb over it and unthread the buffer tube until the retainer is released. Remove the retainer and spring (#19). Continue to unthread the buffer tube from the lower receiver until it is removed.

PARTS VARIANTS

Some models of the Gen-12 use parts unique to that particular model. Some of these parts must be treated differently when assembling or disassembling the shotgun.

Most models are available with dual charging handles as an option. The additional left side charging handle is longer than the right side charging handle in most applications.

- Right side charging handle: 1 3/8”(35mm)
- Left side charging handle: 1 5/8”(41mm)

MBS 7” AOW:

The buffer tube of the MBS 7” AOW is of a proprietary design. The stockless compact buffer system allows for a shorter overall length of the shotgun. Basic disassembly of the upper from the lower must be done in a different manner than Gen-12 shotguns due to this design feature. The procedure for separating the upper from the lower receiver is as follows:

1. Pull the operating handle fully to the rear.
2. While holding the operating handle in its rearmost position, insert a 1/8” punch through the hole located at the rear of the buffer tube. This will capture the buffer to the rear and prevent the buffer and spring from decompressing in an uncontrolled manner when the upper receiver is separated from the lower receiver.
3. Separate the upper receiver from the lower receiver.
4. Securely hold the buffer in the buffer tube and remove the 1/8” punch.
5. Remove the buffer and spring from the buffer tube in a controlled manner.

The process for removal of the stockless compact buffer system is as follows:

1. Unthread the buffer tube counterclockwise from the lower receiver. The AOW housing that the buffer tube locks into can be removed at this point.

When reassembling the buffer tube and AOW housing to the lower receiver, torque the tube 50-55 ft/lbs. No threadlocker is necessary. **Ensure that the tube is not over torqued**, as this can cause the front end of the buffer tube to protrude forward of the lower receiver ring and prevent assembly of the upper receiver to the lower.

PDS 5” SBS:

The PDS 5” SBS utilizes a short buffer tube similar to the MBS 7” AOW however integrates a proprietary compact 2 position PDW stock. The process for basic disassembly of the upper from the lower and removal of the PDW stock is the same as described above for the MBS 7” AOW.

Disassembly of the PDW stock is as follows:

1. Depress the release lever plunger and push the release lever firmly.
2. Slide the butt stock assembly rearward out of the housing.
3. The buttstock can be removed from the housing at this point.

Reassemble in the reverse order and torque the buffer tube 50-55 ft/lbs. Follow the same precautions as with the MBS 7” AOW.

MAGAZINE DISASSEMBLY

1. Depress the spring plate tab located in the center of the magazine base plate with a non-marring punch.
2. Slide the base plate forward. **CAUTION- the magazine spring is under spring pressure and will want to jump out of the magazine housing when the plate is removed.**
3. Remove the base plate, magazine spring and follower.

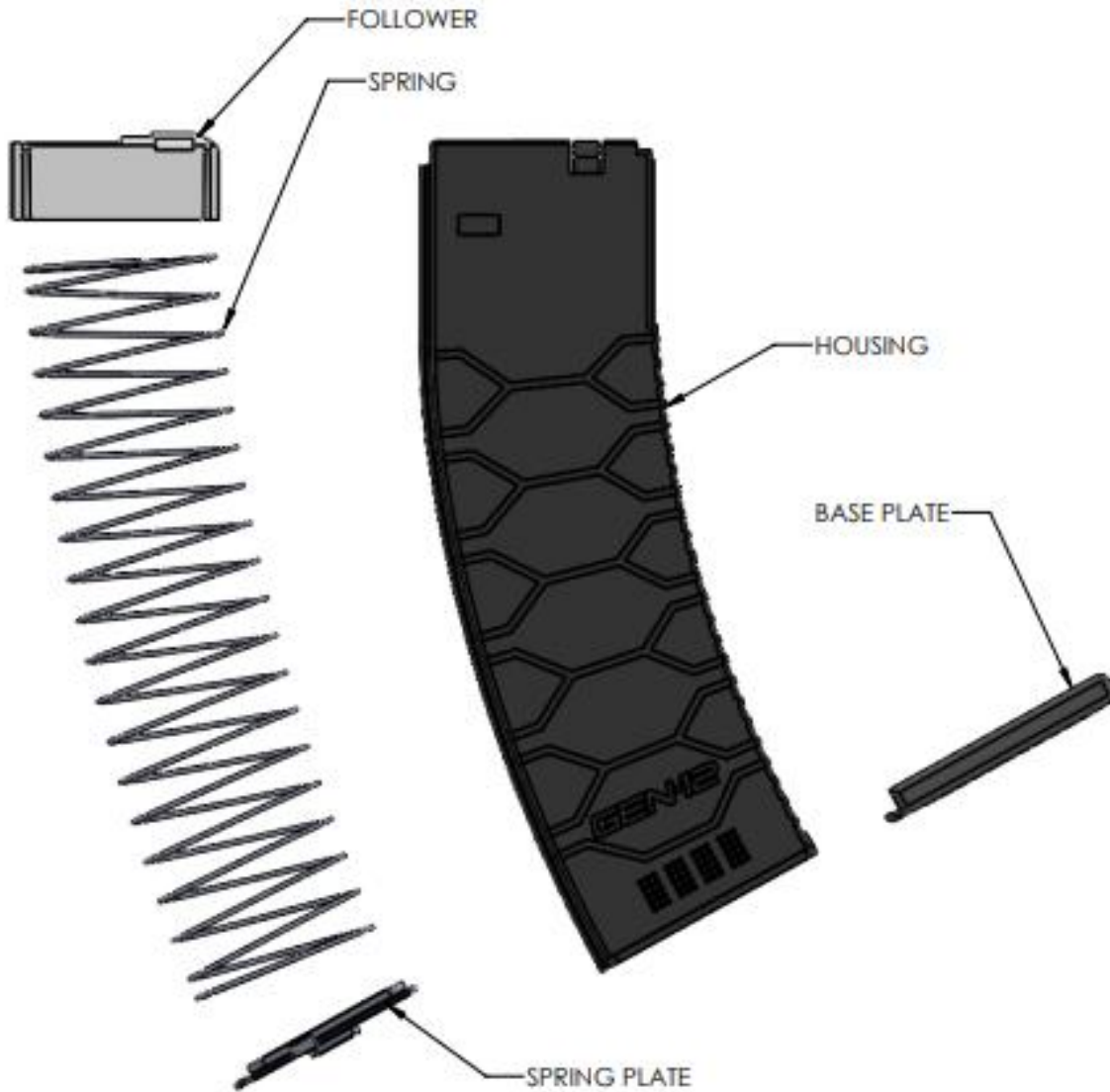

CLEANING

Cleaning the Gen-12 can be performed using many commercially available solvents and products. Ultrasonic cleaning as well as manual cleaning can safely be performed. Abrasives and hard wire brushes should be avoided as they can damage the parts finish and offer little to no advantage when cleaning. Foaming bore cleaners should be used with caution as excess cleaner can creep into the upper receiver around the barrel extension which must remain lubricated for proper function of the Gen-12 short recoil action.

Before working on any firearm, a safety check must be performed. Eye protection is recommended while cleaning the Gen-12.

General cleaning after use should include the following:

- Clean the barrel bore.
- Clean the chamber and locking lug areas of the barrel extension.
- Clean the assembled bolt carrier group including the locking lug areas of the bolt and extractors.
- Wipe out the upper receiver assembly.
- Clean the accessible areas of the lower receiver assembly.

Periodic cleaning should also include:

- Cleaning of the disassembled bolt carrier group.
- Removal of the handguard to clean the outside of the barrel, VIB assembly and barrel extension.
- Disassembly of the fire control system and complete cleaning of its components.
- Cleaning of the buffer assembly.
- Cleaning of the magazine assembly.

LUBRICATION

Lubrication is the utmost importance for the function and longevity of the Gen-12. Good quality gun oil is recommended. Lubrication should be applied to the following:

Upper receiver:

- Interface between the upper receiver and barrel extension.
- Locking lug area of the barrel extension.
- Timing block raceway.
- Wear insert.

Bolt carrier group:

- Extractors.
- Bolt and bolt return spring.
- Cam pin.
- Firing pin and spring.
- External surfaces of the bolt carrier.

Lower receiver:

- Buffer and spring.
- Trigger and hammer pins.
- Bolt catch pivot.
- Selector switch.
- Magazine: NO LUBRICATION.

GEN-12 PDS 5" SBS

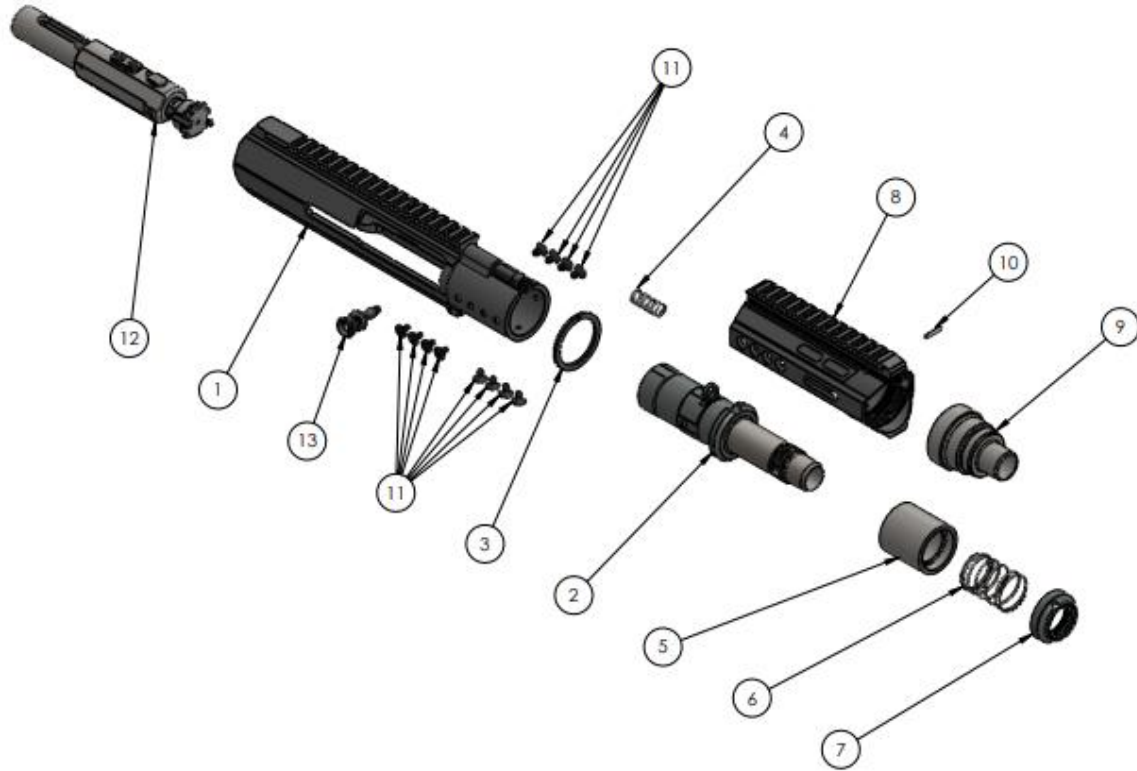

ITEM NO.	PART NUMBER	DESCRIPTION	QTY.
1	G100-38-RH	STRIPPED UPPER RECEIVER ASSY	1
2	G103-84	BARREL ASSEMBLY - 5"	1
3	G101-43	IMPACT RING THRUST WASHER	1
4	G101-01	BARREL STUD RECOIL SPRING	1
5	G101-36-S	5Inch Vib	1
6	G101-39	VIB SPRING	1
7	G101-37-S	5" VIB NUT	1
8	G104-04	HANDGUARD	1
9	G105-90	5IN BARREL BUSHING	1
10	G101-42	BARREL BUSHING PIN	1
11	G101-13	HANDGUARD SCREW	12
12	G100-40-S	PDS CARRIER ASSY	1
13	G101-78	STANDARD CHARGING HANDLE	1

GEN-12 SBM 7" SBS

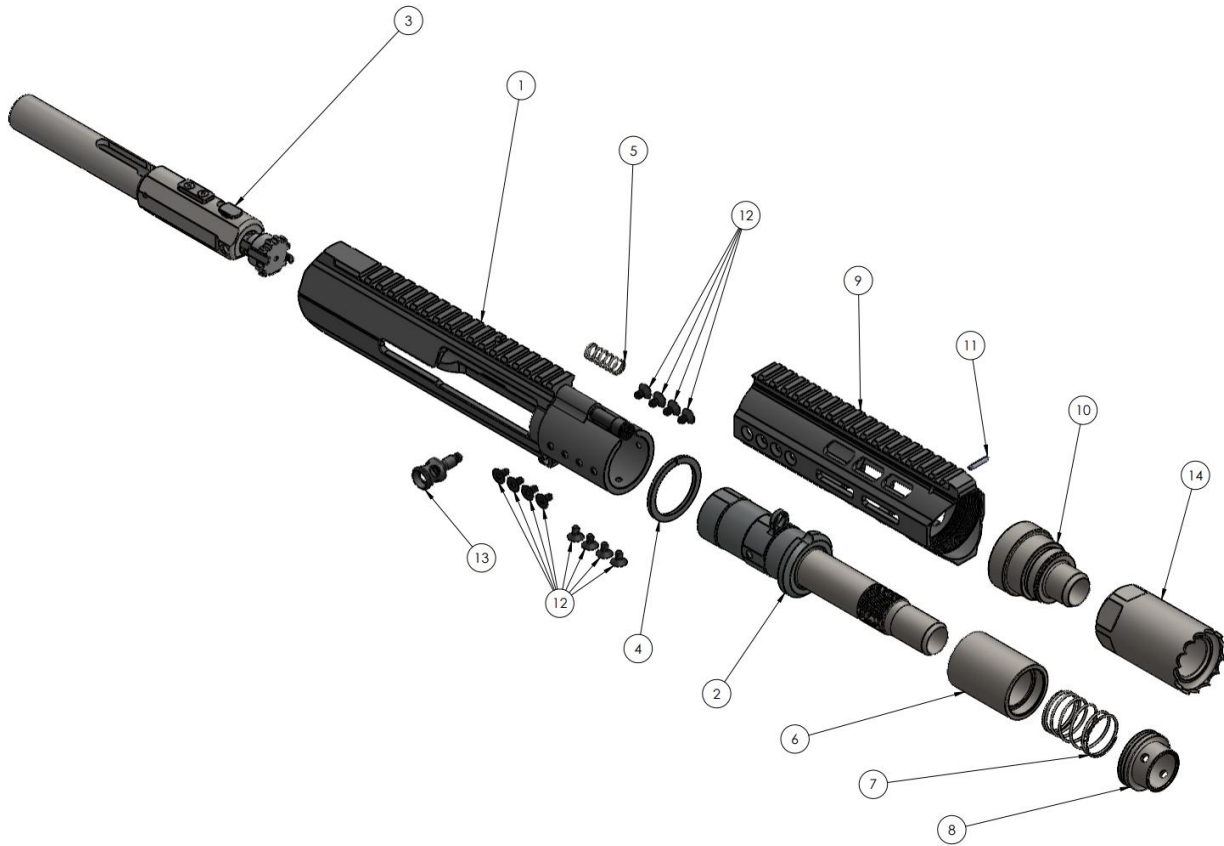

ITEM NO.	PART NUMBER	DESCRIPTION	QTY.
1	G100-38-RH	STRIPPED UPPER RECEIVER ASSY	1
2	G103-11	BARREL ASSEMBLY - 7"	1
3	G103-77	BOLT CARRIER GROUP ASSY	1
4	G101-43	IMPACT RING THRUST WASHER	1
5	G101-01	BARREL STUD RECOIL SPRING	1
6	G101-36	VIB WEIGHT	1
7	G101-39	VIB SPRING	1
8	G101-37	VIB NUT	1
9	G101-11	HANDGUARD - 7"	1
10	G102-90	BARREL BUSHING	1
11	G101-42	BARREL BUSHING PIN	1
12	G101-13	HANDGUARD SCREW	12
13	G101-78	STANDARD CHARGING HANDLE	1
14	G101-93	STEEL BLAST CAN	1

GEN-12 PDS 7" SBS

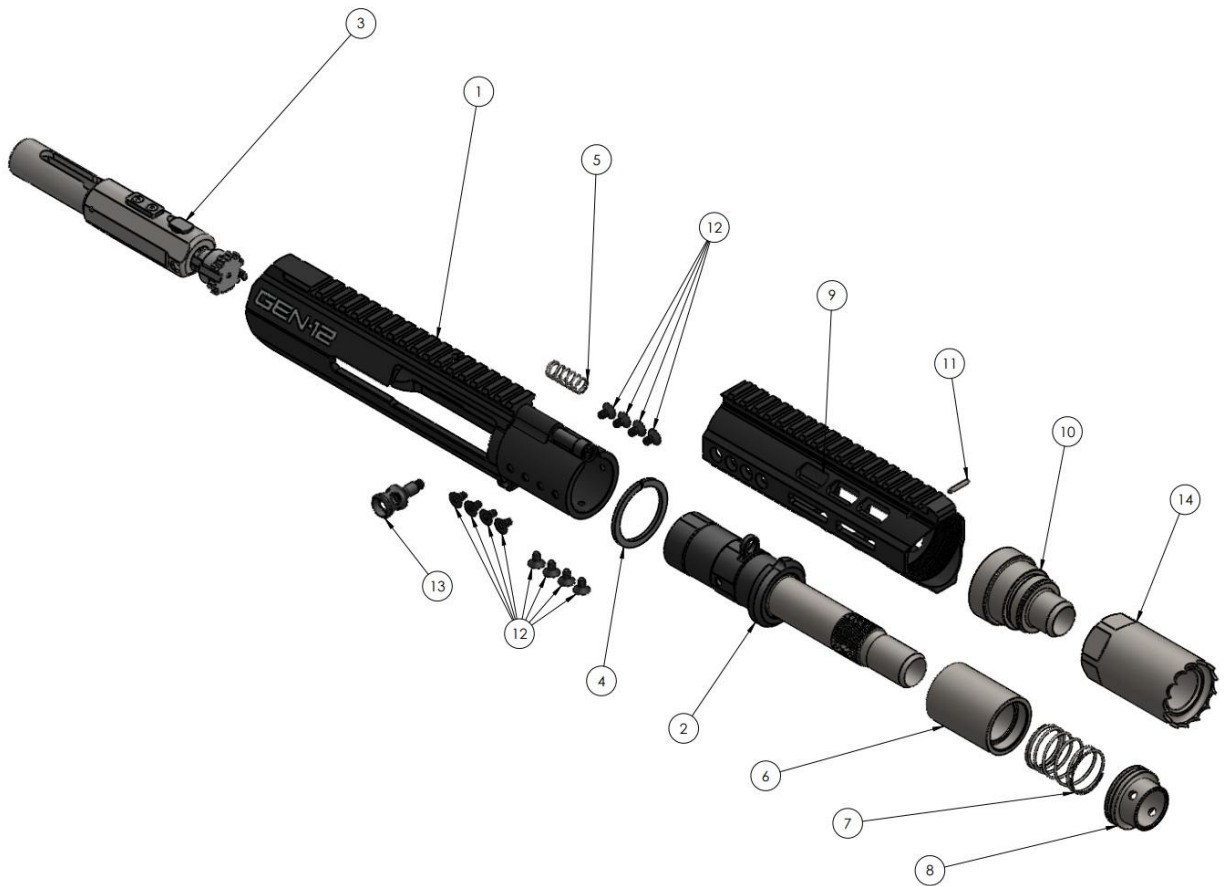

ITEM NO.	PART NUMBER	DESCRIPTION	QTY.
1	G100-38-RH	STRIPPED UPPER RECEIVER ASSY	1
2	G103-11	BARREL ASSEMBLY - 7"	1
3	G100-40-S	PDS CARRIER ASSY	1
4	G101-43	IMPACT RING THRUST WASHER	1
5	G101-01	BARREL STUD RECOIL SPRING	1
6	G101-36	VIB WEIGHT	1
7	G101-39	VIB SPRING	1
8	G101-37	VIB NUT	1
9	G101-11	HANDGUARD - 7"	1
10	G102-90	BARREL BUSHING	1
11	G101-42	BARREL BUSHING PIN	1
12	G101-13	HANDGUARD SCREW	12
13	G101-78	STANDARD CHARGING HANDLE	1
14	G101-93	STEEL BLAST CAN	1

GEN-12 MBS 7" AOW

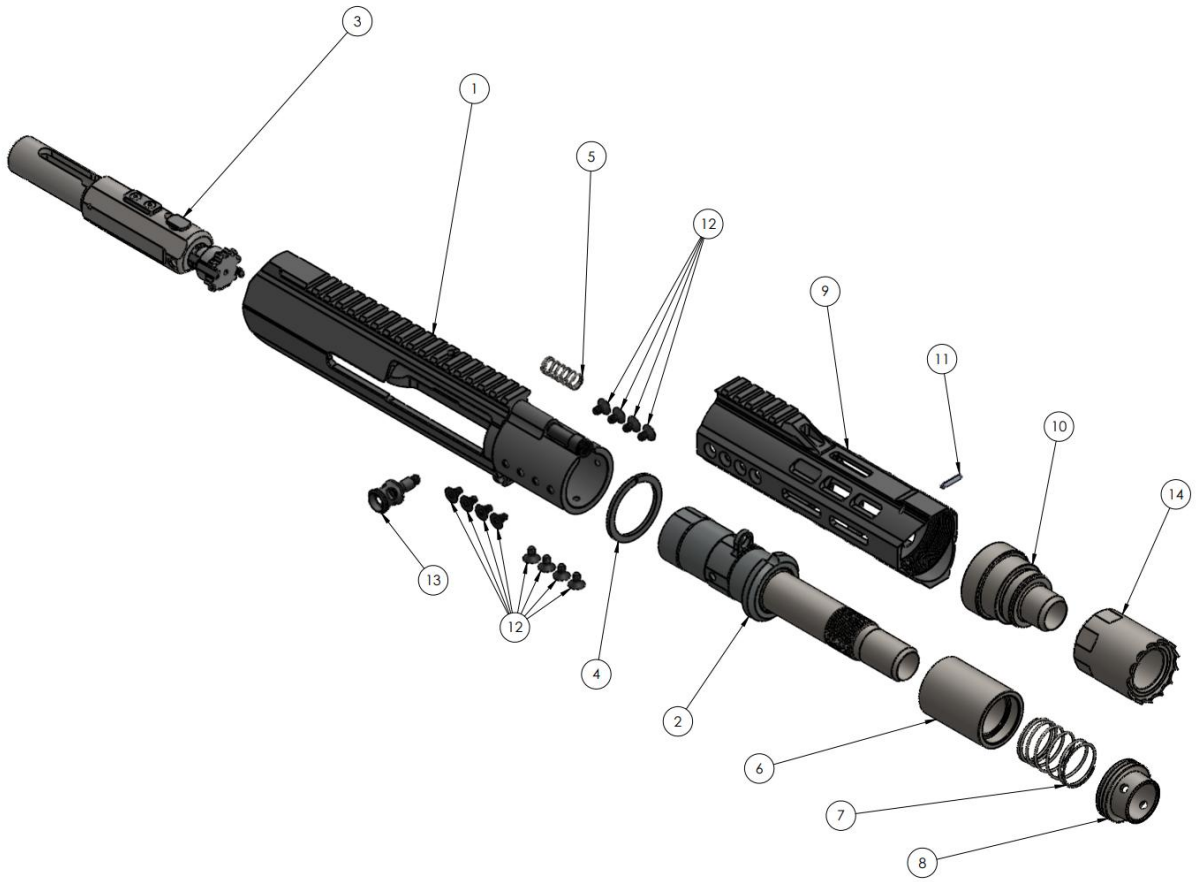

ITEM NO.	PART NUMBER	DESCRIPTION	QTY.
1	G100-38-RH	STRIPPED UPPER RECEIVER ASSY	1
2	G103-11	BARREL ASSEMBLY - 7"	1
3	G100-40-S	PDS CARRIER ASSY	1
4	G101-43	IMPACT RING THRUST WASHER	1
5	G101-01	BARREL STUD RECOIL SPRING	1
6	G101-36	VIB WEIGHT	1
7	G101-39	VIB SPRING	1
8	G101-37	VIB NUT	1
9	G103-62	HANDGUARD - 7" LIGHTWEIGHT	1
10	G102-90	BARREL BUSHING	1
11	G101-42	BARREL BUSHING PIN	1
12	G101-13	HANDGUARD SCREW	12
13	G101-78	STANDARD CHARGING HANDLE	1
14	G101-93M	MICRO BLAST CAN	1

GEN-12 SBM 10.5" SBS

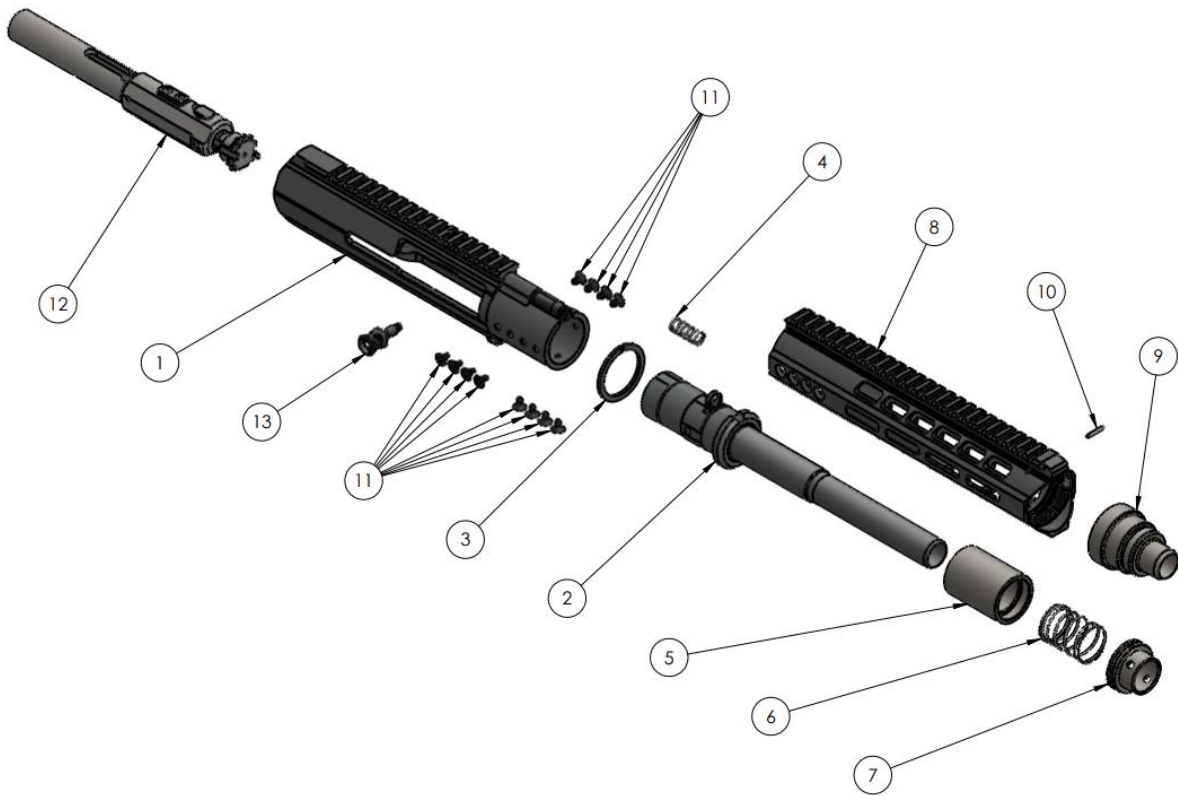

ITEM NO.	PART NUMBER	DESCRIPTION	QTY.
1	G100-38-RH	STRIPPED UPPER RECEIVER ASSY	1
2	G103-04	BARREL ASSEMBLY - 10.5"	1
3	G101-43	IMPACT RING THRUST WASHER	1
4	G101-01	BARREL STUD RECOIL SPRING	1
5	G101-36	VIB WEIGHT	1
6	G101-39	VIB SPRING	1
7	G101-37	VIB NUT	1
8	G101-07	10.5" HANDGUARD STANDARD	1
9	G102-90	BARREL BUSHING	1
10	G101-42	BARREL BUSHING PIN	1
11	G101-13	HANDGUARD SCREW	12
12	G103-77	BOLT CARRIER GROUP ASSY	1
13	G101-78	STANDARD CHARGING HANDLE	1

GEN-12 SBM 14.5"

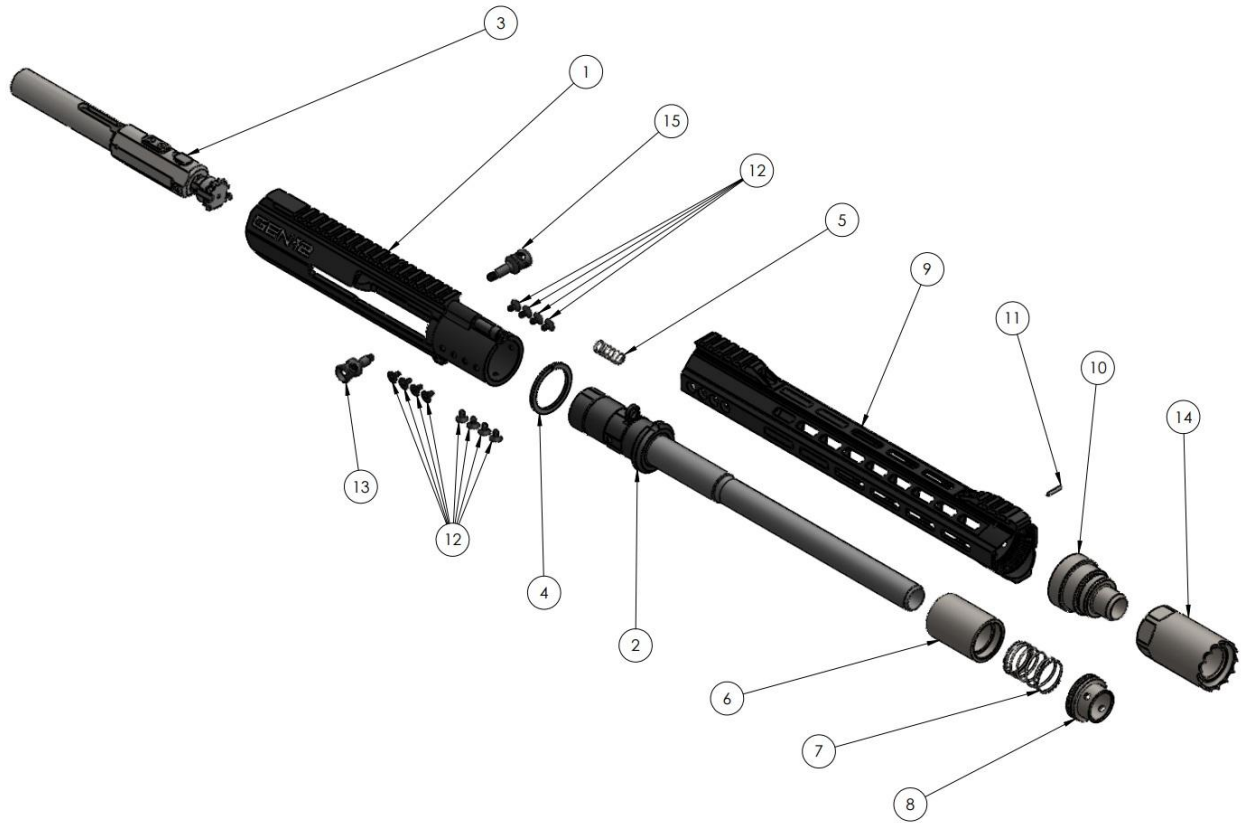

ITEM NO.	PART NUMBER	DESCRIPTION	QTY.
1	G100-38-LH	STRIPPED UPPER RECEIVER ASSY	1
2	G103-09	BARREL ASSEMBLY - 14.5"	1
3	G103-77	BOLT CARRIER GROUP ASSY	1
4	G101-43	IMPACT RING THRUST WASHER	1
5	G101-01	BARREL STUD RECOIL SPRING	1
6	G101-36	VIB WEIGHT	1
7	G101-39	VIB SPRING	1
8	G101-37	VIB NUT	1
9	G103-16	HANDGUARD, 14.5" LW	1
10	G102-90	BARREL BUSHING	1
11	G101-42	BARREL BUSHING PIN	1
12	G101-13	HANDGUARD SCREW	12
13	G101-78	STANDARD CHARGING HANDLE	1
14	G101-93	STEEL BLAST CAN	1
15	G101-78L	LEFT CHARGING HANDLE	1

STANDARD FULL MASS BOLT CARRIER

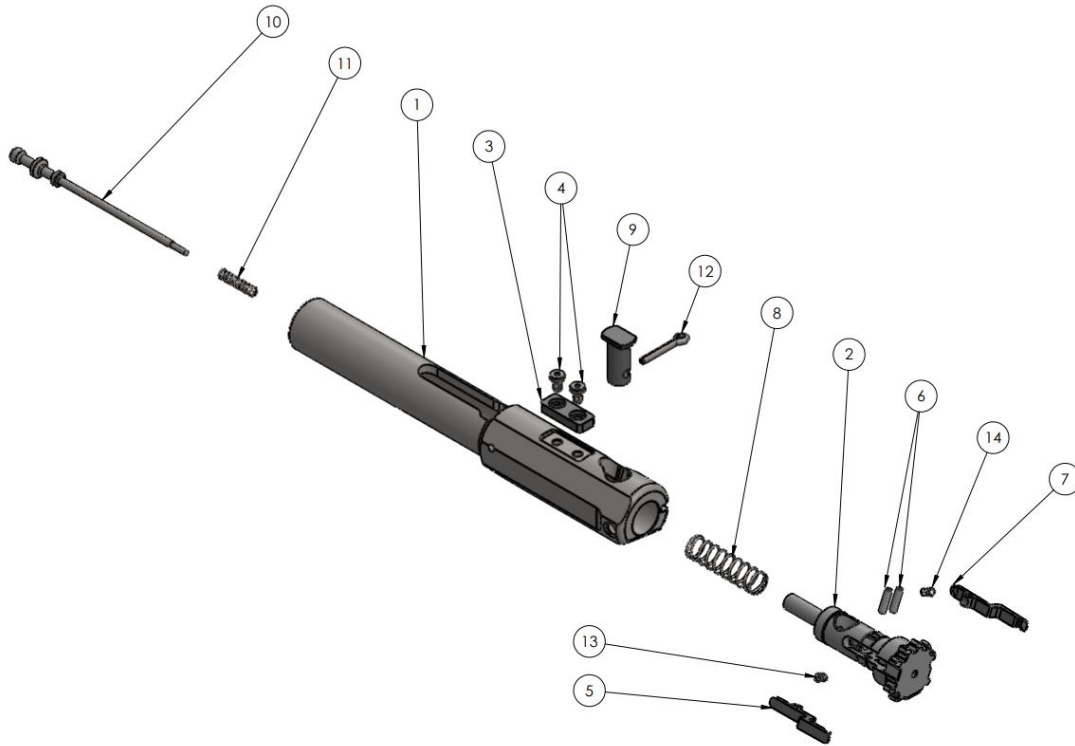

ITEM NO.	PART NUMBER	DESCRIPTION	QTY.
1	G103-21	FULL MASS CARRIER	1
2	G101-58	BOLT	1
3	G101-56	TIMING KEY	1
4	G101-57	TIMING BLOCK SCREW	2
5	G101-61	EXTRACTOR - OUTBOARD	1
6	G101-66	EXTRACTOR PIN	2
7	G101-67	INBOARD EXTRACTOR	1
8	G101-71	BOLT SPRING	1
9	G101-72	CAM PIN	1
10	G101-74	FIRING PIN GEN12	1
11	G101-73	FIRING PIN SPRING	1
12	G101-77	FIRING COTTER PIN	1
13	G101-64	OUTBOARD EXTRACTOR SPRING	1
14	G101-70	INBOARD EXTRACTOR SPRING	1

SHORT BOLT CARRIER

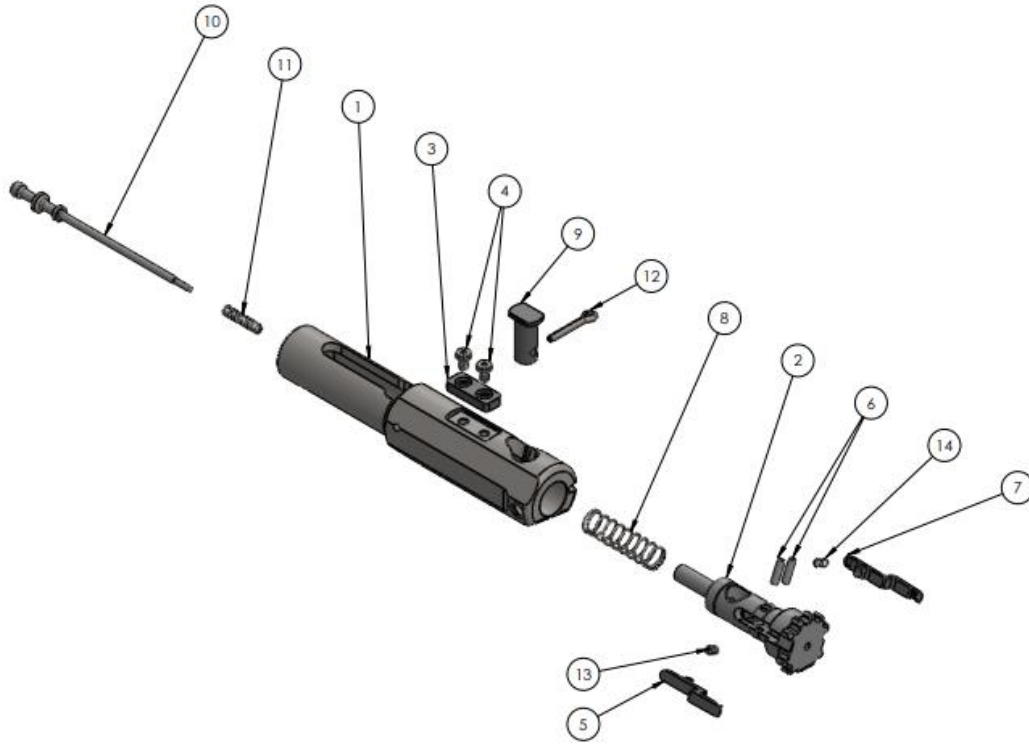

ITEM NO.	PART NUMBER	DESCRIPTION	QTY.
1	G103-22	PDS (SHORT) CARRIER	1
2	G101-58	BOLT	1
3	G101-56	TIMING KEY	1
4	G101-57	TIMING BLOCK SCREW	2
5	G101-61	EXTRACTOR - OUTBOARD	1
6	G101-66	EXTRACTOR PIN	2
7	G101-67	INBOARD EXTRACTOR	1
8	G101-71	BOLT SPRING	1
9	G101-72	CAM PIN	1
10	G101-74	FIRING PIN GEN12	1
11	G101-73	FIRING PIN SPRING	1
12	G101-77	FIRING PIN RETAINER	1
13	G101-64	OUTBOARD EXTRACTOR SPRING	1
14	G101-70	INBOARD EXTRACTOR SPRING	1

STANDARD LOWER RECEIVER

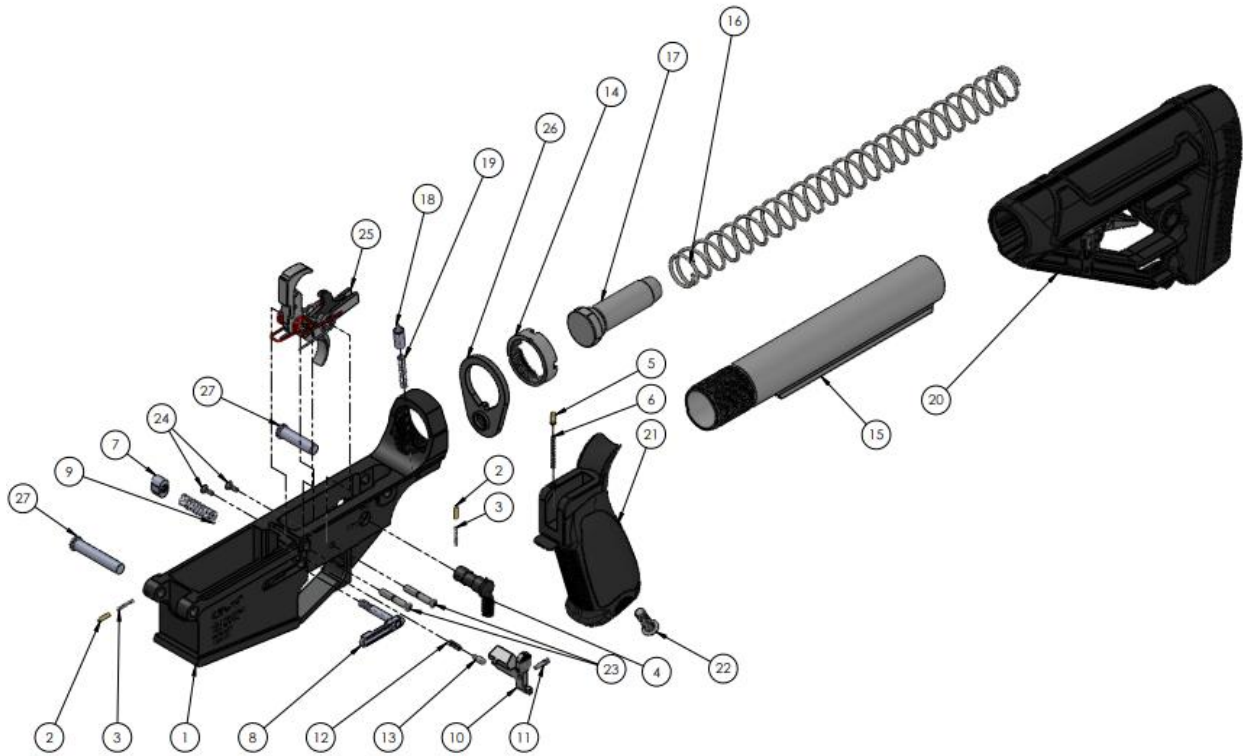

ITEM NO.	PART NUMBER	DESCRIPTION	QTY.				
1	G100-41	LOWER RECEIVER - STRIPPED	1	14	G100-65	CASTLE NUT	1
2	G100-51	TAKEDOWN DETENT	2	15	G100-66	BUFFER TUBE	1
3	G100-52	TAKEDOWN DETENT SPRING	2	16	G100-67	12GA BUFFER SPRING	1
4	W001-05	BAD SAFETY, NON AMBI	1	17	G100-68	BUFFER	1
5	G100-54	SAFETY DETENT	1	18	G100-69	BUFFER RETAINER	1
6	G100-55	SAFETY DETENT SPRING	1	19	G100-70	BUFFER RETAINER SPRING	1
7	G102-36	MAG CATCH BUTTON	1	20	G100-84	BUTTSTOCK - ADAPTIVE	1
8	G102-37	MAG CATCH - IMPROVED	1	21	G100-71	PISTOL GRIP - HOGUE	1
9	G100-58	MAG CATCH SPRING	1	22	G100-73	GRIP SCREW	1
10	G100-59	BOLT CATCH - BAD 308	1	23	G100-74	ANTI WALK PIN	2
11	G100-60	BOLT CATCH SCREW	1	24	G100-75	ANTI WALK PIN SCREW	2
12	G100-61	BOLT CATCH SPRING	1	25	G100-78	HYPERFIRE TRIGGER ASSY	1
13	G100-62	BOLT CATCH PLUNGER	1	26	W001-16	QD ENDPLATE	1
				27	W001-03	TAKE DOWN PIN SET (2)	1

FIREARM LOWER ASSEMBLY

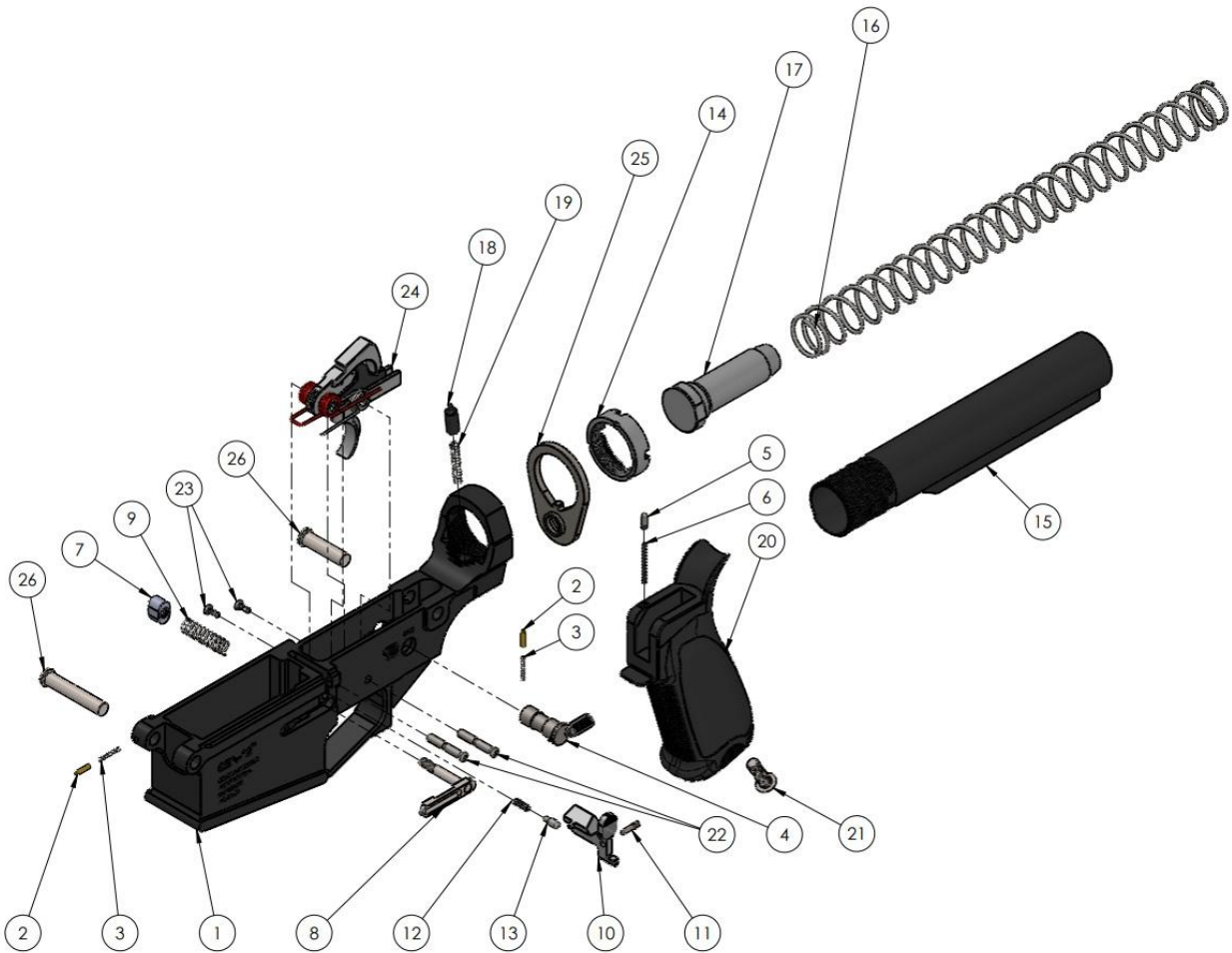

ITEM NO.	PART NUMBER	DESCRIPTION	QTY.
1	G100-41	LOWER RECEIVER STRIPPED	1
2	G100-51	TAKEDOWN DETENT	2
3	G100-52	TAKEDOWN DETENT SPRING	2
4	W001-05	BAD SAFETY, NON AMBI	1
5	G100-54	SAFETY DETENT	1
6	G100-55	SAFETY DETENT SPRING	1
7	G102-36	MAG CATCH BUTTON	1
8	G102-37	MAG CATCH - IMPROVED	1
9	G100-58	MAG CATCH SPRING	1
10	G100-59	BOLT CATCH - BAD 308	1
11	G100-60	BOLT CATCH SCREW	1
12	G100-61	BOLT CATCH SPRING	1
13	G100-62	BOLT CATCH PLUNGER	1
14	G100-65	CASTLE NUT	1
15	G100-66	BUFFER TUBE, CARBINE	1
16	G100-67	12GA BUFFER SPRING	1
17	G100-68	BUFFER	1
18	G100-69	BUFFER RETAINER	1
19	G100-70	BUFFER RETAINER SPRING	1
20	G100-71	PISTOL GRIP - HOGUE	1
21	G100-73	GRIP SCREW	1
22	G100-74	ANTI WALK PIN	2
23	G100-75	ANTI WALK PIN SCREW	2
24	G100-78	HYPERFIRE TRIGGER ASSY	1
25	W001-16	QD ENDPLATE	1
26	W001-03	TAKE DOWN PIN SET (2)	1

PDS LOWER RECEIVER

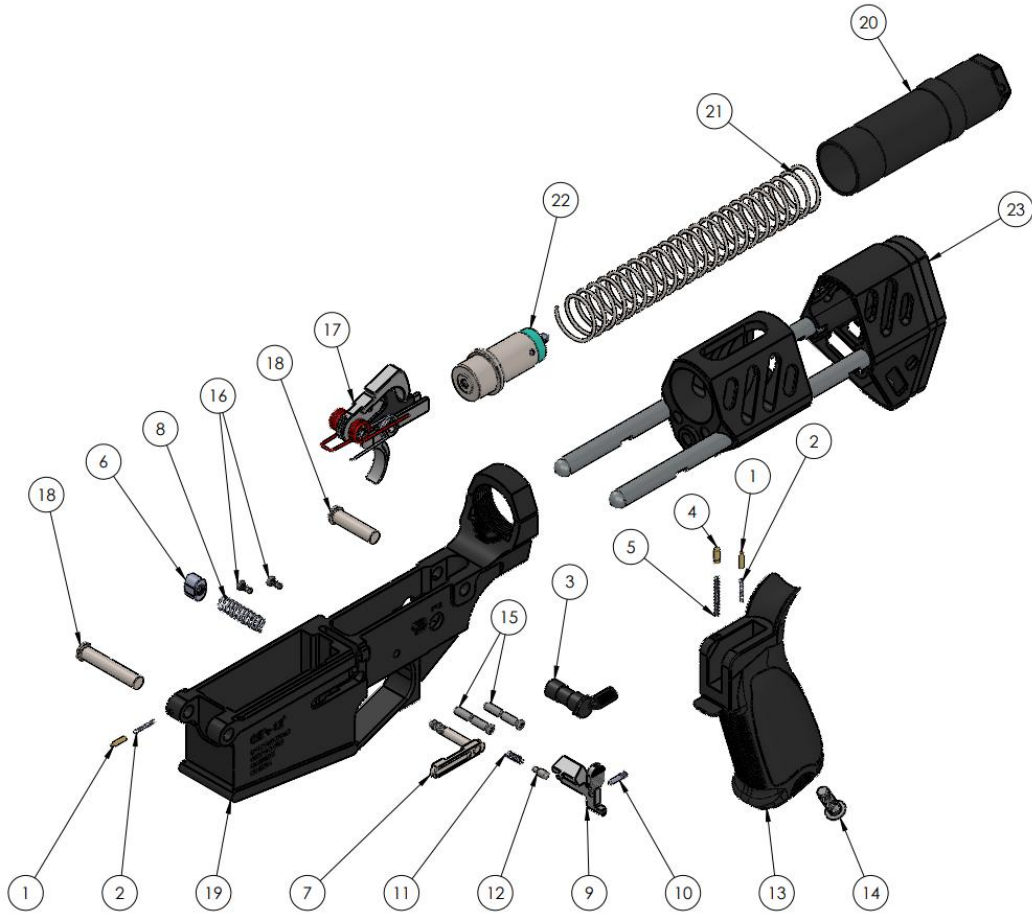

ITEM NO.	PART NUMBER	DESCRIPTION	QTY.
1	G100-51	TAKEDOWN DETENT	2
2	G100-52	TAKEDOWN DETENT SPRING	2
3	W001-05	BAD SAFETY, NON AMBI	1
4	G100-54	SAFETY DETENT	1
5	G100-55	SAFETY DETENT SPRING	1
6	G102-36	MAG CATCH BUTTON	1
7	G102-37	MAG CATCH - IMPROVED	1
8	G100-58	MAG CATCH SPRING	1
9	G100-59	BOLT CATCH - BAD 308	1
10	G100-60	BOLT CATCH SCREW	1
11	G100-61	BOLT CATCH SPRING	1
12	G100-62	BOLT CATCH PLUNGER	1
13	G100-71	PISTOL GRIP - HOGUE	1
14	G100-73	GRIP SCREW	1
15	G100-74	ANTI WALK PIN	2
16	G100-75	ANTI WALK PIN SCREW	2
17	G100-78	HYPERFIRE TRIGGER ASSY	1
18	W001-03	TAKE DOWN PIN SET (2)	1
19	G100-41-PDW5	LOWER RECEIVER, 5" SBS	1
20	G100-66-C	PDW BUFFER TUBE	1
21	G103-79	PDW BUFFER SPRING	1
22	G103-56	PDW BUFFER ASSEMBLY	1
23	G200-01	PDW STOCK ASSY	1

PDS STOCK ASSEMBLY

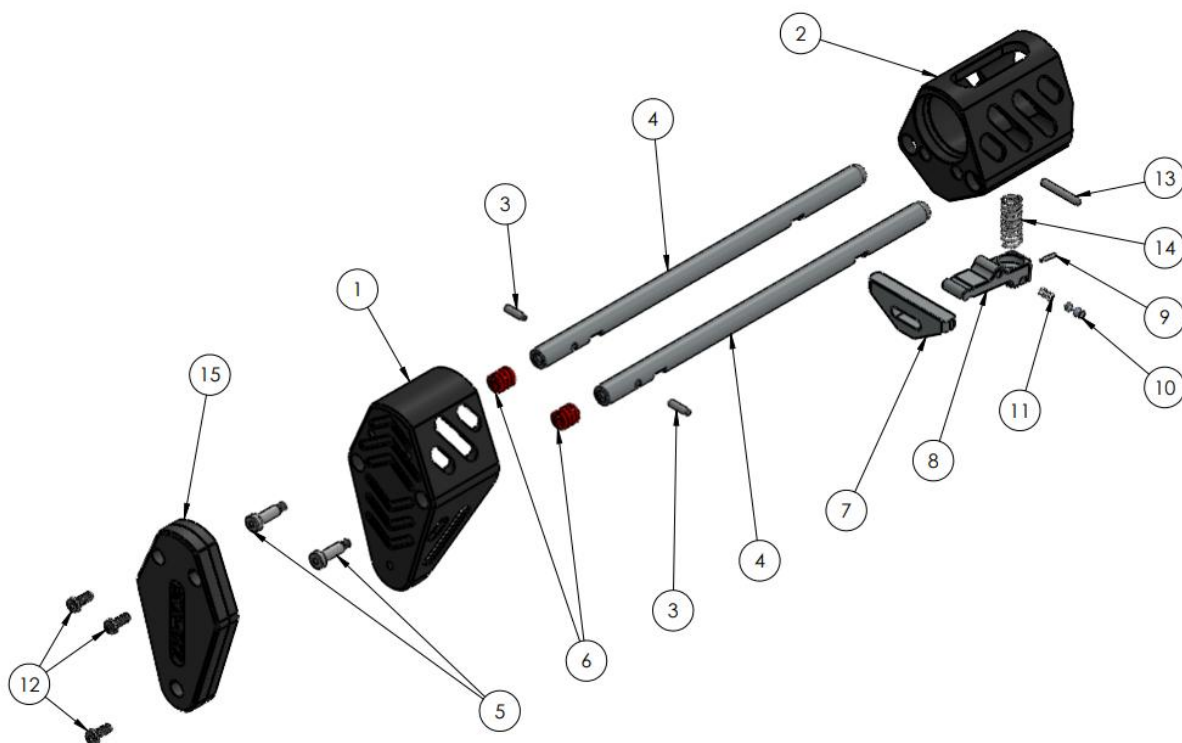

ITEM NO.	PART NUMBER	DESCRIPTION	QTY.
1	G100-87	PDW BUTT STOCK	1
2	G100-88	PDW HOUSING	1
3	G101-66	EXTRACTOR PIN	2
4	G103-99	PDW ROD	2
5	G103-99-S	SHOULDER SCREW - PDW	2
6	G103-99-SPRING	PDW ROD SPRING	2
7	G104-01	PDW LOCKING BLOCK	1
8	G104-02	PDW RELEASE LEVER	1
9	G104-18	SLOTTED SPRING PIN	1
10	G104-19	RELEASE LEVER PLUNGER	1
11	G104-20	COMP SPRING - PDW PLUNGER	1
12	G104-21	LOW PROFILE SHCS	3
13	G104-22	DOWEL PIN	1
14	G104-23	COMP SPRING - PDW LEVER	1
15	KZ-GENESIS-PDW	PDW BUTT PAD	1

AOW LOWER RECEIVER

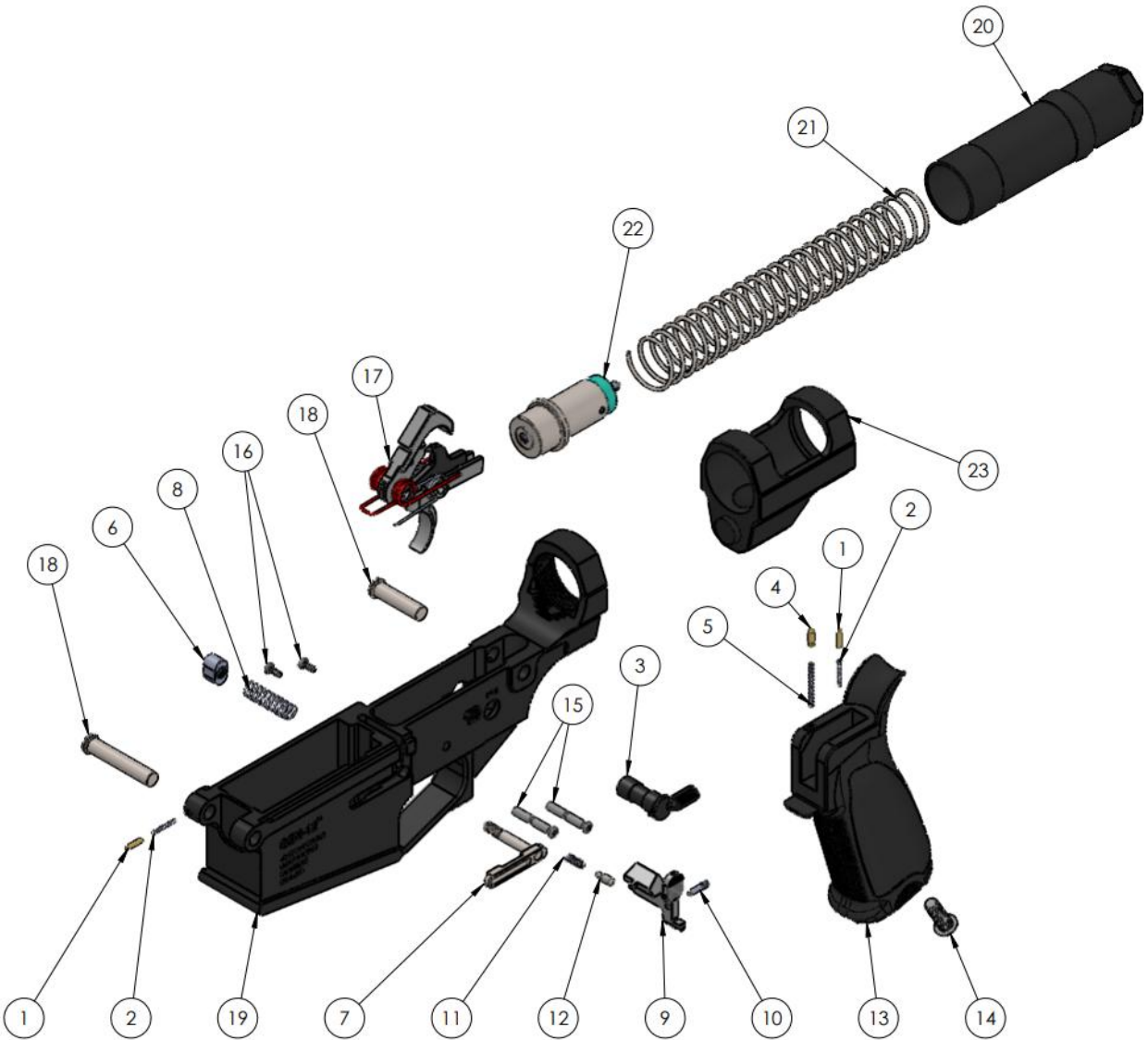

ITEM NO.	PART NUMBER	DESCRIPTION	QTY.		
		12	G100-62	BOLT CATCH PLUNGER	1
1	G100-51	TAKEDOWN DETENT	2		
2	G100-52	TAKEDOWN DETENT SPRING	2		
3	W001-05	BAD SAFETY, NON AMBI	1		
4	G100-54	SAFETY DETENT	1		
5	G100-55	SAFETY DETENT SPRING	1		
6	G102-36	MAG CATCH BUTTON	1		
7	G102-37	MAG CATCH - IMPROVED	1		
8	G100-58	MAG CATCH SPRING	1		
9	G100-59	BOLT CATCH - BAD 308	1		
10	G100-60	BOLT CATCH SCREW	1		
11	G100-61	BOLT CATCH SPRING	1		
		13	G100-71	PISTOL GRIP - HOGUE	1
		14	G100-73	GRIP SCREW	1
		15	G100-74	ANTI WALK PIN	2
		16	G100-75	ANTI WALK PIN SCREW	2
		17	G100-78	HYPERFIRE TRIGGER ASSY	1
		18	W001-03	TAKE DOWN PIN SET (2)	1
		19	G100-41-SBS7	7" MBS AOW LOWER RECEIVER	1
		20	G100-66-C	PDW BUFFER TUBE	1
		21	G103-79	PDW BUFFER SPRING	1
		22	G103-56	PDW BUFFER ASSEMBLY	1
		23	G100-66-CH	MBS BUFFER TUBE HOUSING	1

WARRANTY

GENESIS ARMS WARRANTIES ITS PRODUCTS TO BE FREE FROM DEFECTS IN MATERIALS OR WORKMANSHIP

Limited Warranty Covers the Original Retail Buyer

For one (1) year plus fourteen (14) days from the date of purchase, Genesis Arms will repair or replace (as determined by Genesis Arms) any Genesis Arms OEM product, bought directly from Genesis Arms or a Genesis Arms authorized dealer, which fails under normal use.

NOT COVERED:

- Products and accessories not purchased from Genesis Arms or Genesis Arms authorized dealer
- Normal wear and tear and cosmetic damage due to use
- Damage or failure due to unauthorized repairs, modifications, alterations, abuse, negligent use or lack of routine maintenance or care
- Damage or failure due to the use of reloaded (“reloads”), altered or defective ammunition

ADDITIONAL INFORMATION

The Genesis Arms Limited Warranty is provided in lieu of any and all expressed warranties. All implied warranties, including merchantability, non-infringement and fitness for a particular purpose are limited to the duration, terms and conditions of the Limited Warranty period. No warranties expressed or implied will apply after the duration of the Limited Warranty period. Some states do not allow limitations on the duration of an implied warranty. The preceding limitation of duration may not apply in your home state.

Under the terms of its Limited Warranty, Genesis Arms’ responsibility for any malfunction or defects in the product is limited to repair or replacement. The Limited Warranty constitutes Genesis Arms’ only obligation to you and your exclusive remedy against Genesis Arms. In no event will Genesis Arms be liable for incidental, special or consequential damages, regardless of whether your claims are based on contract, tort or other theories, including without limitation, any liability for economic loss, bodily injury, property damage or any damage that may result from your use or ownership of a Genesis Arms product, whether foreseeable or not.

Some states do not allow the exclusion or limitation of incidental or consequential damages or certain other exclusions contained in warranties. The preceding limitations and exclusions may not apply in your home state. The declared limitations and exclusions apply to the fullest extent allowed by law.

The Genesis Arms Limited Warranty gives you specific legal rights. You may have other rights which vary from state to state. No person or business is authorized by Genesis Arms to modify any term of the Limited Warranty.

For Warranty Work or Questions:

Contact Genesis Arms support@genesisarms.com for Limited Warranty information or to request service. A merchandise return authorization from Genesis Arms is required. Unauthorized returns will not be accepted. When you contact Genesis Arms, please identify the product, serial number, date and place of purchase and a detailed description of the issue. Shipping and insurance charges will be paid by Genesis Arms for products repaired or replaced under its Limited Warranty.

Warranty Dispute Resolution:

Any dispute regarding the Limited Warranty will be resolved at the sole discretion of GENESIS ARMS LLC.

PURCHASE INFORMATION

SERIAL NUMBER: _____

DATE OF PURCHASE: _____

- INTERNET PURCHASE
 - GENESISARMS.COM
 - OTHER ONLINE RETAILER

RETAILER
WEBSITE: _____

RETAIL STORE

NAME: _____

ADDRESS: _____

CITY: _____ STATE: _____ ZIP: _____

PHONE: _____